



Product Data

Upflow/Horizontal Left/Right, Dedicated Downflow Two Stage Condensing Gas Fired Furnace

Upflow, Convertible to
Horizontal Right or
Horizontal Left
S9V2B040U3PSC
S9V2B060U4PSC
S9V2B080U4PSC
S9V2C080U5PSC
S9V2C100U5PSC
S9V2D120U5PSC

Downflow Only
S9V2B040D3PSC
S9V2B060D3PSC
S9V2B080D4PSC
S9V2C100D5PSC
S9V2D120D5PSC

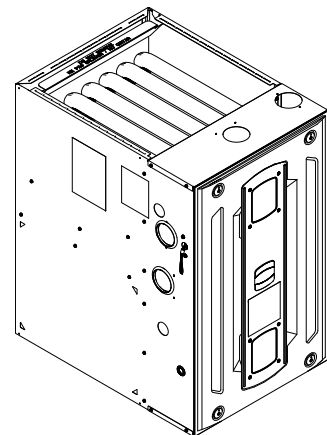

Note: Graphics in this document are for representation only. Actual model may differ in appearance.

⚠ WARNING

FIRE HAZARD!

Failure to follow this Warning could result in property damage, severe personal injury, or death.
This Warning applies to installations with a flammable refrigeration system.
The furnace must be powered except for service. The furnace shall be installed and connected according to installation instructions and wiring diagrams that are provided with the evaporator coil.

⚠ CAUTION

COIL REQUIREMENT!

Failure to follow this Caution could result in property damage or personal injury. 4GXC* and 4MXC* coils installed on upflow furnaces in vertical, horizontal left, or horizontal right orientations without a factory installed metal drain pan shield must use a MAY*FERCOLKITAA kit. Coils installed on upflow furnaces must have drain pans that are suitable for 400° F (205°C) or have a metal drain pan shield. Downflow furnaces do not require a metal drain pan shield or the use of the MAY*FERCOLKITAA kit. See Installer's Guide for more information.



Table of Contents

General Features	3
Features and Benefits.....	4
Accessories.....	6
Product Specification	7
Heating and Cooling Airflow Tables	13
Maximum Vent Length Table	28
S9V2 Wiring Diagram.....	29
Electrical Connections	30
Field Wiring	30
Outline Drawings	32



General Features

NATURAL GAS MODELS

Central Heating furnace designs are certified by the Intertek/ETL for both natural and propane gas. Limit setting and rating data were established and approved under standard rating conditions using American National Standards Institute standards.

SAFE OPERATION

The Integrated Furnace Control is a solid state device which continuously monitors for presence of flame when the system is in the heating mode of operation. Dual solenoid combination gas valve and regulator provide additional safety.

QUICK HEATING

Durable, cycle tested, heavy gauge **tubular stainless steel primary heat exchanger** quickly transfers heat to provide warm conditioned air to the structure. **Low energy power vent blower**, to increase efficiency and provide a positive discharge of gas fumes to the outside.

BURNERS

Multiport Inshot burners will give years of quiet and efficient service. All models can be converted to **Propane** with propane conversion kit.

INTEGRATED FURNACE CONTROL

Exclusively designed operational program provides total control of furnace limit sensors, blowers, gas valve, flame control and includes self diagnostics for ease of service. Also contains dry contacts for EAC and HUM.

ENERGY EFFICIENT OPERATION

Furnace is certified by the manufacturer to leak 1% or less of nominal air conditioning CFM delivered when pressurized to 0.5 inch water column with all inlets, outlets, and drains sealed.

AIR DELIVERY

The variable speed blower motor has sufficient airflow for most heating and cooling requirements and will switch from heating to cooling speeds on demand from room thermostat.

SECONDARY HEAT EXCHANGER

The S-Series furnace has a special type 29- 4C™ stainless steel secondary heat exchanger to reclaim heat from flue gases which would normally be lost.

STYLING

Heavy gauge steel and "wrap-around" cabinet construction is used in the cabinet with baked-on enamel finish for strength and beauty. Every orientation has at least two venting options. There are no knockouts on cabinet.

FEATURES AND GENERAL OPERATION

The S-Series furnace utilizes a Silicon Nitride Hot Surface Ignition system, which eliminates the waste of a constant burning pilot. The integrated furnace control lights the main burners upon a demand for heat from the room thermostat. Complete front service access.

- a. Low energy power venter
- b. Vent proving pressure switches.



Features and Benefits

96.0% AFUE ACROSS ALL MODELS

Meets utility rebates

Lowers utility bills

ELECTRICALLY EFFICIENT

Efficient airflow design reduces electrical energy use

34 INCH TALL

Lighter, easier to move and fit into tight spaces like short basements or tight closets

Works great with larger, high-efficiency coils

No knockouts

3-WAY MULTI-POISE / DEDICATED DOWNFLOW

6 SKU's — Upflow / Horizontal Left / Horizontal Right

5 SKU's — Downflow

Added application flexibility and reduction in specification errors

AIRFLOW

At least 400 CFM/ton at 0.5 in. H₂O external static pressure; setup airflow options down to 290 CFM/ton

REGULATORY

All models are air tight; 1% or less air leakage as per ASHRAE 193

Open vestibule design provides a full 34" high open vestibule

DIMENSIONS

Widths are industry standard: 17.5", 21", and 24.5"

Depth remains approximately 28"

Cabinet will be compatible with industry standard coils, as well as, other accessories

INTEGRATED FURNACE CONTROL

Setup / Status / Diagnostics / Digital Display

No dip switches

Last six errors stored

Dry contact EAC and HUM connections

All multi-pin polarized terminals connections; no spade terminals

Low voltage labeled above and below

TUBULAR STAINLESS STEEL PRIMARY HEAT EXCHANGER

29-4C STAINLESS STEEL SECONDARY HEAT EXCHANGER

Stainless steel is a more durable, corrosive-resistant material than aluminumized steel

Integrated rail system for easy access if required

Reduces or eliminates need for baffles

VORTICA BLOWER, DESIGNED EXCLUSIVELY FOR THE S-SERIES FURNACE

Improved airflow efficiency

Durable, easy to clean, two piece housing

Single piece belly band/ motor arm assembly

Blower deck has full-length rails for easy removal and replacement, regardless of poise

THREE-WAY MULTI-POISE (UPFLOW, HORIZONTAL LEFT AND RIGHT) PLUS DEDICATED DOWNFLOW

Easier to specify

Shipped ready to install (no kits required)

Every model has at least two venting options

Barbed fitting on trap at hose connection and on cabinet transition for hose has barbed fitting and clamps at both ends for leak resistance.

Vent table improvements including longer vent lengths; 2" pipe can be used up to 100K



Accessories

Table 1. Accessories

Model Number	Description	Use with
BAYHANG	Horizontal Hanging Kit	All Upflow Furnaces
BAYVENT200B	Sidewall Vent Termination Kit	All Furnaces
BAYVENTCN200B	Sidewall Vent Termination Kit (Canada – CPVC)	All Furnaces
BAYAIR30AVENTA	Concentric Vent Kit	All Furnaces
BAYAIR30CNVENT	Concentric Vent Kit (Canada – CPVC)	All Furnaces
BAYFLTR203	Horizontal Filter Kit	B Cabinet Modular Blowers in Downflow/ Horizontal
BAYFLTR204	Horizontal Filter Kit	C Cabinet Modular Blowers in Downflow/ Horizontal
BAYFLTR205	Horizontal Filter Kit	D Cabinet Modular Blowers in Downflow/ Horizontal
BAYFLTR206	Filter Access Door Kit (Downflow only)	All Furnaces in Downflow orientation
BAYREDUCE	Reducing Coupling (CPVC)	All Furnaces
BAYLIFTB	Dual Return Kit (B size extension)	B Cabinet Upflow Furnaces
BAYLIFTC	Dual Return Kit (C size extension)	C Cabinet Upflow Furnaces
BAYLIFTD	Dual Return Kit (D size extension)	D Cabinet Upflow Furnaces
BAYBASE205	Downflow Subbase	All Downflow Furnaces
BAYFLTR206	Filter Access Door Kit (Downflow only)	All Downflow Furnaces
BAYSF1165A* ^(a)	1" SlimFit Box with MERV 4 Filter	All Upflow Furnaces
BAYSF1255*	2" SlimFit Filter Box with MERV 4 Filter	All furnaces when used in side return application. B-Cabinet Furnaces only when in bottom return application.
BAYLPSS400*	Propane Conversion Kit with Stainless Steel Burners	All Furnaces
BAYMFGH200B	Manufactured/Mobile Housing Kit	All Furnaces
BAYCNDTRAP2A	Inline Condensate Trap Kit used with Special Venting on 2" Vent Pipe	All Furnaces
BAYCNDTRAP3A	Inline Condensate Trap Kit used with Special Venting on 3" Vent Pipe	All Furnaces
FLRSF1255	1" Filter replacement (Qty 12)	BAYSF1255*

^(a) Airflow greater than 1600 CFM requires dual returns



Product Specification

Model	S9V2B040U3PSC (a), (b)	S9V2B060U4PSC (a), (b)	S9V2B080U4PSC (a), (b)
Type	Upflow / Horizontal	Upflow / Horizontal	Upflow / Horizontal
RATINGS (c)			
1st Stage Input BTUH	26,000	39,000	52,000
1st Stage Capacity BTUH (ICS)	25,300	38,100	50,500
2nd Stage Input BTUH	40,000	60,000	80,000
2nd Stage Capacity BTUH (ICS) (d)	38,950	58,400	77,700
1st Stage Temp. Rise (Min. - Max.) °F	25 - 55	25 - 55	30 - 60
2nd Stage Temp. Rise (Min. - Max.) °F	30 - 60	35 - 65	35 - 65
AFUE (%) (d)	96.0	96.0	96.0
Return Air Temp. (Min. - Max.) °F	45°F - 80°F	45°F - 80°F	45°F - 80°F
BLOWER DRIVE	DIRECT	DIRECT	DIRECT
Diameter - Width (in.)	11 X 8	11 X 8	11 X 8
No. Used	1	1	1
Speeds (No.)	Variable	Variable	Variable
CFM vs. in. w.g.	See Fan Performance Table	See Fan Performance Table	See Fan Performance Table
Motor HP	1/2	3/4	3/4
R.P.M.	Variable	Variable	Variable
Volts / Ph / Hz	120 / 1 / 60	120 / 1 / 60	120 / 1 / 60
FLA	5.7 / 6.4	8 / 9.6	8 / 9.6
COMBUSTION FAN - Type	PSC	PSC	PSC
Drive - No. Speeds	Direct - 2	Direct - 2	Direct - 2
Motor RPM	3300/2600	3300/2600	3300/2600
Volts/Ph/Hz	120 / 1 / 60	120 / 1 / 60	120 / 1 / 60
FLA	0.66	0.66	0.66
Inducer Orifice	0.61	0.79	0.96
FILTER - Furnished?	No	No	No
Type Recommended	High Velocity	High Velocity	High Velocity
Hi Vel. (No.-Size-Thk.)	1 - 16 X 25 - 1 in.	1 - 16 X 25 - 1 in.	1 - 16 X 25 - 1 in.
VENT OUTLET DIAMETER - MIN. (in.) (e)	2 Round	2 Round	2 Round
INLET AIR DIAMETER - MIN. (in.) (e)	2 Round	2 Round	2 Round
HEAT EXCHANGER - Type			
Fired	409 Stainless Steel	409 Stainless Steel	409 Stainless Steel
Unfired	29-4C Stainless Steel	29-4C Stainless Steel	29-4C Stainless Steel
Gauge (Fired)	20	20	20
ORIFICES - Main			
Nat. Gas (Qty. - Drill Size)	2 - 45	3 - 45	4 - 45



Product Specification

Model	S9V2B040U3PSC (a), (b)	S9V2B060U4PSC (a), (b)	S9V2B080U4PSC (a), (b)
Propane Gas (Qty. - Drill Size)	2 - 5/6	3 - 5/6	4 - 5/6
GAS VALVE	Redundant - Two Stage	Redundant - Two Stage	Redundant - Two Stage
PILOT SAFETY DEVICE – Type	120 V SiNi Igniter	120 V SiNi Igniter	120 V SiNi Igniter
BURNERS - TYPE - QTY	Inshot - 2	Inshot - 3	Inshot - 4
POWER CONN. - V/Ph/HZ^(f)	120 / 1 / 60	120 / 1 / 60	120 / 1 / 60
Ampacity (Amps)	7.9 / 8.8	10.8 / 12.8	10.8 / 12.8
Max. Overcurrent Protection (Amps)	15	15	15
PIPE CONN. SIZE (IN.)	1/2	1/2	1/2
DIMENSIONS	H x W x D	H x W x D	H x W x D
Uncrated (in.)	34 x 17-1/2 x 28-3/4	34 x 17-1/2 x 28-3/4	34 x 17-1/2 x 28-3/4
Crated (in.)	35-1/2 x 19-1/2 x 30-7/8	35-1/2 x 19-1/2 x 30-7/8	35-1/2 x 19-1/2 x 30-7/8
WEIGHT			
Shipping (Lbs.)/Net (Lbs.)	122/114	130/122	135/127

(a) Meets Energy Star

(b) Central Furnace heating designs are certified to ANSI Z21.47 / CSA 2.3 - latest edition.

(c) For U.S. Applications, above input ratings (BTUH) are up to 2,000 feet, derate 4% per 1,000 feet for elevations above 2,000 feet above sea level. For Canadian applications, above input ratings (BTUH) are up to 4,500 feet, derate 4% per 1,000 feet for elevations above 4,500 feet above sea level.

(d) Based on U.S. government standard tests.

(e) Refer to Vent Length Table in the Installer's Guide.

(f) The above wiring specifications are in accordance with National Electrical Code; however, installations must comply with local codes.

Model	S9V2C080U5PSC (a), (b)	S9V2C100U5PSC (a), (b)	S9V2D120U5PSC (a), (b)
Type	Upflow / Horizontal	Upflow / Horizontal	Upflow / Horizontal
RATINGS^(c)			
1st Stage Input BTUH	52,000	65,000	78,000
1st Stage Capacity BTUH (ICS)	50,600	63,400	75,500
2nd Stage Input BTUH	80,000	100,000	120,000
2nd Stage Capacity BTUH (ICS) ^(d)	77,750	97,650	115,700
1st Stage Temp. Rise (Min. - Max.) °F	30 - 60	25 - 55	35 - 65
2nd Stage Temp. Rise (Min. - Max.) °F	35 - 65	30 - 60	40 - 70
AFUE (%) ^(d)	96.0	96.0	96.0
Return Air Temp. (Min. - Max.) °F	45°F - 80°F	45°F - 80°F	45°F - 80°F
BLOWER DRIVE	DIRECT	DIRECT	DIRECT
Diameter - Width (in.)	11 X 10	11 X 10	11 X 10
No. Used	1	1	1
Speeds (No.)	Variable	Variable	Variable
CFM vs. in. w.g.	See Fan Performance Table	See Fan Performance Table	See Fan Performance Table
Motor HP	1	1	1
R.P.M.	Variable	Variable	Variable
Volts / Ph / Hz	120 / 1 / 60	120 / 1 / 60	120 / 1 / 60
FLA	10.5 / 10	10.5 / 10	10.5 / 10



Product Specification

Model	S9V2C080U5PSC (a), (b)	S9V2C100U5PSC (a), (b)	S9V2D120U5PSC (a), (b)
COMBUSTION FAN - Type	PSC	PSC	PSC
Drive - No. Speeds	Direct - 2	Direct - 2	Direct - 2
Motor RPM	3300/2600	3300/2600	3300/2600
Volts/Ph/Hz	120 / 1 / 60	120 / 1 / 60	120 / 1 / 60
FLA	0.66	0.66	0.66
Inducer Orifice	0.88	1.05	1.19
FILTER - Furnished?	No	No	No
Type Recommended	High Velocity	High Velocity	High Velocity
Hi Vel. (No.-Size-Thk.)	1 - 20 X 25 - 1 in.	1 - 20 X 25 - 1 in.	1 - 24 X 25 - 1 in.
VENT OUTLET DIAMETER - MIN. (in.) ^(e)	2 Round	2 Round	3 Round
INLET AIR DIAMETER - MIN. (in.) ^(e)	2 Round	2 Round	3 Round
HEAT EXCHANGER - Type			
Fired	409 Stainless Steel	409 Stainless Steel	409 Stainless Steel
Unfired	29-4C Stainless Steel	29-4C Stainless Steel	29-4C Stainless Steel
Gauge (Fired)	20	20	20
ORIFICES - Main			
Nat. Gas (Qty. - Drill Size)	4 - 45	5 - 45	6 - 45
Propane Gas (Qty. - Drill Size)	4 - 56	5 - 56	6 - 56
GAS VALVE	Redundant - Two Stage	Redundant - Two Stage	Redundant - Two Stage
PILOT SAFETY DEVICE - Type	120 V SiNi Igniter	120 V SiNi Igniter	120 V SiNi Igniter
BURNERS - TYPE - QTY	Inshot - 4	Inshot - 5	Inshot - 6
POWER CONN. - V/Ph/HZ ^(f)	120 / 1 / 60	120 / 1 / 60	120 / 1 / 60
Ampacity (Amps)	13.9 / 13.3	13.9 / 13.3	13.9 / 13.3
Max. Overcurrent Protection (Amps)	15	15	15
PIPE CONN. SIZE (IN.)	1/2	1/2	1/2
DIMENSIONS	H x W x D	H x W x D	H x W x D
Uncrated (in.)	34 x 21 x 28-3/4	34 x 21 x 28-3/4	34 x 24-1/2 x 28-3/4
Crated (in.)	35-1/2 x 23 x 30-7/8	35-1/2 x 23 x 30-7/8	35-1/2 x 26-1/2 x 30-7/8
WEIGHT			
Shipping (Lbs.)/Net (Lbs.)	149/139	155/145	167/156

(a) Meets Energy Star

(b) Central Furnace heating designs are certified to ANSI Z21.47 / CSA 2.3 - latest edition.

(c) For U.S. Applications, above input ratings (BTUH) are up to 2,000 feet, derate 4% per 1,000 feet for elevations above 2,000 feet above sea level. For Canadian applications, above input ratings (BTUH) are up to 4,500 feet, derate 4% per 1,000 feet for elevations above 4,500 feet above sea level.

(d) Based on U.S. government standard tests.

(e) Refer to Vent Length Table in the Installer's Guide.

(f) The above wiring specifications are in accordance with National Electrical Code; however, installations must comply with local codes.

Model	S9V2B040D3PSC (a), (b)	S9V2B060D3PSC (a), (b)	S9V2B080D4PSC (a), (b)
Type	Downflow	Downflow	Downflow
RATINGS ^(c)			



Product Specification

Model	S9V2B040D3PSC (a), (b)	S9V2B060D3PSC (a), (b)	S9V2B080D4PSC (a), (b)
1st Stage Input BTUH	26,000	39,000	52,000
1st Stage Capacity BTUH (ICS)	25,300	37,700	50,300
2nd Stage Input BTUH	40,000	60,000	80,000
2nd Stage Capacity BTUH (ICS) ^(d)	38,850	57,850	77,350
1st Stage Temp. Rise (Min. - Max.) °F	25 - 55	25 - 55	30 - 60
2nd Stage Temp. Rise (Min. - Max.) °F	30 - 60	35 - 65	35 - 65
AFUE (%) ^(d)	96.0	96.0	96.0
Return Air Temp. (Min. - Max.) °F	45°F - 80°F	45°F - 80°F	45°F - 80°F
BLOWER DRIVE	DIRECT	DIRECT	DIRECT
Diameter - Width (in.)	11 X 8	11 X 8	11 X 8
No. Used	1	1	1
Speeds (No.)	Variable	Variable	Variable
CFM vs. in. w.g.	See Fan Performance Table	See Fan Performance Table	See Fan Performance Table
Motor HP	1/2	1/2	3/4
R.P.M.	Variable	Variable	Variable
Volts / Ph / Hz	120 / 1 / 60	120 / 1 / 60	120 / 1 / 60
FLA	5.7 / 6.4	5.7 / 6.4	8 / 9.6
COMBUSTION FAN - Type	PSC	PSC	PSC
Drive - No. Speeds	Direct - 2	Direct - 2	Direct - 2
Motor RPM	3300/2600	3300/2600	3300/2600
Volts/Ph/Hz	120 / 1 / 60	120 / 1 / 60	120 / 1 / 60
FLA	0.66	0.66	0.66
Inducer Orifice	0.61	0.79	0.96
FILTER - Furnished?	No	No	No
Type Recommended	High Velocity	High Velocity	High Velocity
Hi Vel. (No.-Size-Thk.)	1 - 16 X 25 - 1 in.	1 - 16 X 25 - 1 in.	1 - 16 X 25 - 1 in.
VENT OUTLET DIAMETER - MIN. (in.) ^(e)	2 Round	2 Round	2 Round
INLET AIR DIAMETER - MIN. (in.) ^(e)	2 Round	2 Round	2 Round
HEAT EXCHANGER - Type			
Fired	409 Stainless Steel	409 Stainless Steel	409 Stainless Steel
Unfired	29-4C Stainless Steel	29-4C Stainless Steel	29-4C Stainless Steel
Gauge (Fired)	20	20	20
ORIFICES - Main			
Nat. Gas (Qty. - Drill Size)	2 - 45	3 - 45	4 - 45
Propane Gas (Qty. - Drill Size)	2 - 56	3 - 56	4 - 56
GAS VALVE	Redundant - Two Stage	Redundant - Two Stage	Redundant - Two Stage
PILOT SAFETY DEVICE			
Type	120 V SiNi Igniter	120 V SiNi Igniter	120 V SiNi Igniter



Product Specification

Model	S9V2B040D3PSC (a), (b)	S9V2B060D3PSC (a), (b)	S9V2B080D4PSC (a), (b)
BURNERS - TYPE - QTY	Inshot - 2	Inshot - 3	Inshot - 4
POWER CONN. - V/Ph/HZ ^(f)	120 / 1 / 60	120 / 1 / 60	120 / 1 / 60
Ampacity (Amps)	7.9 / 8.8	7.9 / 8.8	10.8 / 12.8
Max. Overcurrent Protection (Amps)	15	15	15
PIPE CONN. SIZE (IN.)	1/2	1/2	1/2
DIMENSIONS	H x W x D	H x W x D	H x W x D
Uncrated (in.)	34 x 17-1/2 x 28-3/4	34 x 17-1/2 x 28-3/4	34 x 17-1/2 x 28-3/4
Crated (in.)	35-1/2 x 19-1/2 x 30-7/8	35-1/2 x 19-1/2 x 30-7/8	35-1/2 x 19-1/2 x 30-7/8
WEIGHT			
Shipping (Lbs.)/Net (Lbs.)	122/114	127/119	135/127

(a) Meets Energy Star

(b) Central Furnace heating designs are certified to ANSI Z21.47 / CSA 2.3 - latest edition.

(c) For U.S. Applications, above input ratings (BTUH) are up to 2,000 feet, derate 4% per 1,000 feet for elevations above 2,000 feet above sea level. For Canadian applications, above input ratings (BTUH) are up to 4,500 feet, derate 4% per 1,000 feet for elevations above 4,500 feet above sea level.

(d) Based on U.S. government standard tests.

(e) Refer to Vent Length Table in the Installer's Guide.

(f) The above wiring specifications are in accordance with National Electrical Code; however, installations must comply with local codes.

Model	S9V2C100D5PSC (a), (b)	S9V2D120D5PSC (a), (b)
Type	Downflow	Downflow
RATINGS ^(c)		
1st Stage Input BTUH	65,000	78,000
1st Stage Capacity BTUH (ICS)	63,300	75,800
2nd Stage Input BTUH	100,000	120,000
2nd Stage Capacity BTUH (ICS) ^(d)	97,150	116,100
1st Stage Temp. Rise (Min. - Max.) °F	30 - 60	30-60
2nd Stage Temp. Rise (Min. - Max.) °F	35 - 65	35-65
AFUE (%) ^(d)	96.0	96.0
Return Air Temp. (Min. - Max.) °F	45°F - 80°F	45°F - 80°F
BLOWER DRIVE	DIRECT	DIRECT
Diameter - Width (in.)	11 X 10	11 X 10
No. Used	1	1
Speeds (No.)	Variable	Variable
CFM vs. in. w.g.	See Fan Performance Table	See Fan Performance Table
Motor HP	1	1
R.P.M.	Variable	Variable
Volts / Ph / Hz	120 / 1 / 60	120 / 1 / 60
FLA	10.5 / 10	10.5 / 10
COMBUSTION FAN - Type	PSC	PSC
Drive - No. Speeds	Direct - 2	Direct - 2
Motor RPM	3300/2600	3300/2600



Product Specification

Model	S9V2C100D5PSC (a), (b)	S9V2D120D5PSC (a), (b)
Volts/Ph/Hz	120 / 1 / 60	120 / 1 / 60
FLA	0.66	0.66
Inducer Orifice	1.05	1.19
FILTER - Furnished?	No	No
Type Recommended	High Velocity	High Velocity
Hi Vel. (No.-Size-Thk.)	1 - 20 X 25 - 1 in.	1 - 24 X 25 - 1 in.
VENT OUTLET DIAMETER - MIN. (in.) (e)	2 Round	3 Round
INLET AIR DIAMETER - MIN. (in.) (e)	2 Round	3 Round
HEAT EXCHANGER - Type		
Fired	409 Stainless Steel	409 Stainless Steel
Unfired	29-4C Stainless Steel	29-4C Stainless Steel
Gauge (Fired)	20	20
ORIFICES - Main		
Nat. Gas (Qty. - Drill Size)	5 - 45	6 - 45
Propane Gas (Qty. - Drill Size)	5 - 56	6 - 56
GAS VALVE	Redundant - Two Stage	Redundant - Two Stage
PILOT SAFETY DEVICE - Type	120 V SiNi Igniter	120 V SiNi Igniter
BURNERS - TYPE - QTY	Inshot - 5	Inshot - 6
POWER CONN. - V/Ph/HZ (f)	120 / 1 / 60	120 / 1 / 60
Ampacity (Amps)	13.9 / 13.3	13.9 / 13.3
Max. Overcurrent Protection (Amps)	15	15
PIPE CONN. SIZE (IN.)	1/2	1/2
DIMENSIONS	H x W x D	H x W x D
Uncrated (in.)	34 x 21 x 28-3/4	34 x 24-1/2 x 28-3/4
Crated (in.)	35-1/2 x 23 x 30-7/8	35-1/2 x 26-1/2 x 30-7/8
WEIGHT		
Shipping (Lbs.)/Net (Lbs.)	155/145	167/156

(a) Meets Energy Star

(b) Central Furnace heating designs are certified to ANSI Z21.47 / CSA 2.3 - latest edition.

(c) For U.S. Applications, above input ratings (BTUH) are up to 2,000 feet, derate 4% per 1,000 feet for elevations above 2,000 feet above sea level. For Canadian applications, above input ratings (BTUH) are up to 4,500 feet, derate 4% per 1,000 feet for elevations above 4,500 feet above sea level.

(d) Based on U.S. government standard tests.

(e) Refer to Vent Length Table in the Installer's Guide.

(f) The above wiring specifications are in accordance with National Electrical Code; however, installations must comply with local codes.



Heating and Cooling Airflow Tables

Table 2. S9V2B040U3PSC Heating Airflow

S9V2B040U3PSC Furnace Heating Airflow (CFM), Temp. Rise (°F), and Power (Watts) vs. External Static Pressure with Filter (iwc)								
				1st Stage Capacity = 25,300 2nd Stage Capacity = 38,950				
				External Static Pressure				
Heating	Airflow Setting	Target Airflow		0.1	0.3	0.5	0.7	0.9
Heating 1st Stage	Low	468	CFM	468	452	437	421	406
			Temp. Rise	49	51	54	56	58
			Watts	27	58	90	121	152
	Medium Low	598	CFM	552	600	647	694	741
			Temp. Rise	43	39	36	32	28
			Watts	41	76	112	147	183
	Medium (a)	634	CFM	583	635	687	739	791
			Temp. Rise	39	36	33	30	27
			Watts	48	83	118	153	189
	High	864	CFM	753	786	818	850	883
			Temp. Rise	30	29	28	27	26
			Watts	87	129	171	214	256
Heating 2nd Stage	Low	650	CFM	633	636	639	643	646
			Temp. Rise	57	57	57	56	56
			Watts	48	92	135	179	223
	Medium Low	830	CFM	760	786	813	840	866
			Temp. Rise	48	46	45	43	41
			Watts	82	132	182	232	282
	Medium (a)	880	CFM	792	817	842	867	892
			Temp. Rise	44	44	43	43	42
			Watts	94	142	189	237	284
	High	1200	CFM	1023	1044	1066	1088	1109
			Temp. Rise	34	34	33	33	32
			Watts	192	251	310	369	428

(a) Factory Setting.

Table 3. S9V2B040D3PSC Heating Airflow

S9V2B040D3PSC Furnace Heating Airflow (CFM), Temp. Rise (°F), and Power (Watts) vs. External Static Pressure with Filter (iwc)								
				1st Stage Capacity = 25,300 2nd Stage Capacity = 38,850				
				External Static Pressure				
Heating	Airflow Setting	Target Airflow		0.1	0.3	0.5	0.7	0.9
Heating 1st Stage	Low	468	CFM	464	453	442	431	420
			Temp. Rise	51	52	53	54	55
			Watts	26	55	84	113	142
	Medium Low (a)	634	CFM	616	607	599	591	583
			Temp. Rise	38	38	39	40	40
			Watts	40	78	115	152	190
	Medium	684	CFM	635	643	650	658	666
			Temp. Rise	37	37	36	36	35
			Watts	47	106	165	224	283
	High	900	CFM	824	843	861	880	898
			Temp. Rise	28	28	27	26	26
			Watts	82	130	178	226	274
Heating 2nd Stage	Low	650	CFM	662	655	649	642	635
			Temp. Rise	54	55	55	56	56
			Watts	37	79	120	162	203
	Medium Low (a)	880	CFM	811	818	826	834	841
			Temp. Rise	45	44	44	43	42
			Watts	67	121	176	230	284
	Medium	950	CFM	859	865	871	877	884
			Temp. Rise	42	41	41	41	41
			Watts	88	144	200	256	312
	High	1250	CFM	1082	1092	1102	1111	1121
			Temp. Rise	33	33	33	33	33
			Watts	192	253	314	375	436

(a) Factory Setting.



Heating and Cooling Airflow Tables

Table 4. S9V2B040U3PSC/ S9V2B040D3PSC Cooling Airflow

S9V2B040U3PSC / S9V2B040D3PSC Furnace Cooling Airflow (CFM) and Power (Watts) vs. External Static Pressure with Filter (iwc)								
Cooling	Unit Outdoor	Airflow Setting (CFM/ton)		External Static Pressure				
				0.1	0.3	0.5	0.7	0.9
Cooling	1.5 Ton	Cooling 450	CFM	675	675	675	675	675
		CFM/Ton	Watts	47	81	121	166	215
		Cooling 420	CFM	630	630	630	630	630
		CFM/Ton	Watts	40	72	111	154	202
		Cooling 400	CFM	600	600	600	600	600
		CFM/Ton	Watts	36	67	105	147	193
		Cooling 370	CFM	555	555	555	555	555
		CFM/Ton	Watts	30	60	96	136	181
		Cooling 350	CFM	525	525	525	525	525
		CFM/Ton	Watts	27	56	90	130	174
		Cooling 330	CFM	495	495	495	495	495
		CFM/Ton	Watts	24	51	85	124	167
		Cooling 310	CFM	465	465	465	465	465
		CFM/Ton	Watts	21	48	80	118	161
		Cooling 290	CFM	435	435	435	435	435
		CFM/Ton	Watts	19	44	76	113	155
Cooling	2.0 Ton	Cooling 450	CFM	900	900	900	900	900
		CFM/Ton	Watts	94	137	186	240	298
		Cooling 420	CFM	840	840	840	840	840
		CFM/Ton	Watts	79	120	166	218	273
		Cooling 400	CFM	800	800	800	800	800
		CFM/Ton	Watts	70	109	154	204	258
		Cooling 370	CFM	740	740	740	740	740
		CFM/Ton	Watts	58	95	138	185	236
		Cooling 350	CFM	700	700	700	700	700
		CFM/Ton	Watts	51	86	127	173	223
		Cooling 330	CFM	660	660	660	660	660
		CFM/Ton	Watts	44	78	118	162	211
		Cooling 310	CFM	620	620	620	620	620
		CFM/Ton	Watts	38	71	109	152	199
		Cooling 290	CFM	580	580	580	580	580
		CFM/Ton	Watts	33	64	101	142	188
Cooling	2.5 Ton	Cooling 450	CFM	1125	1125	1125	1125	1125
		CFM/Ton	Watts	167	219	278	341	408
		Cooling 420	CFM	1050	1050	1050	1050	1050
		CFM/Ton	Watts	139	188	244	304	368
		Cooling 400	CFM	1000	1000	1000	1000	1000
		CFM/Ton	Watts	123	170	223	281	343
		Cooling 370	CFM	925	925	925	925	925
		CFM/Ton	Watts	100	145	195	250	308
		Cooling 350	CFM	875	875	875	875	875
		CFM/Ton	Watts	87	129	178	230	287
		Cooling 330	CFM	825	825	825	825	825
		CFM/Ton	Watts	121	160	205	254	308
		Cooling 310	CFM	775	775	775	775	775
		CFM/Ton	Watts	101	139	182	229	281
		Cooling 290	CFM	725	725	725	725	725
		CFM/Ton	Watts	88	123	164	210	260
Cooling	3.0 Ton ^(a)	Cooling 450	CFM	1350	1350	1350	1298	1198
		CFM/Ton	Watts	272	334	402	440	450
		Cooling 420	CFM	1260	1260	1260	1260	1198
		CFM/Ton	Watts	226	284	348	417	450
		Cooling 400	CFM	1200	1200	1200	1200	1198
		CFM/Ton	Watts	198	254	315	381	450
		Cooling 370	CFM	1110	1110	1110	1110	1110
		CFM/Ton	Watts	161	213	271	333	399
		Cooling 350	CFM	1050	1050	1050	1050	1050
		CFM/Ton ^(a)	Watts	139	188	244	304	368
		Cooling 330	CFM	990	990	990	990	990
		CFM/Ton	Watts	119	166	219	277	338
		Cooling 310	CFM	930	930	930	930	930
		CFM/Ton	Watts	102	146	197	252	311
		Cooling 290	CFM	870	870	870	870	870
		CFM/Ton	Watts	86	128	176	229	285

^(a) Factory Setting.

Heating and Cooling Airflow Tables

Table 5. S9V2B060D3PSC Heating Airflow

S9V2B060D3PSC Furnace Heating Airflow (CFM), Temp. Rise (°F), and Power (Watts) vs. External Static Pressure with Filter (iwc)								
				1st Stage Capacity = 37,700 2nd Stage Capacity = 57,850				
Heating	Airflow Setting	Target Airflow		External Static Pressure				
				0.1	0.3	0.5	0.7	0.9
Heating 1st Stage	Low	711	CFM	677	677	678	678	678
			Temp. Rise	52	52	52	52	52
			Watts	49	94	139	184	229
	Medium Low ^(a)	814	CFM	787	775	763	751	739
			Temp. Rise	45	46	47	48	49
			Watts	71	116	160	205	249
	Medium	893	CFM	865	856	846	837	827
			Temp. Rise	41	41	42	42	43
			Watts	86	134	182	230	278
	High	1067	CFM	1033	1013	994	974	955
			Temp. Rise	35	35	36	36	37
			Watts	141	193	245	297	349
Heating 2nd Stage	Low	900	CFM	859	856	853	850	847
			Temp. Rise	63	63	63	63	63
			Watts	90	139	188	237	287
	Medium Low ^(a)	1030	CFM	977	967	958	948	938
			Temp. Rise	55	56	57	57	58
			Watts	126	179	232	285	338
	Medium	1130	CFM	1067	1053	1040	1027	1013
			Temp. Rise	51	52	52	53	54
			Watts	162	219	275	332	388
	High	1350	CFM	1246	1234	1222	1209	1197
			Temp. Rise	44	44	44	45	45
			Watts	279	333	387	440	494

^(a) Factory Setting.

Table 6. S9V2B060D3PSC Cooling Airflow

S9V2B060D3PSC Furnace Cooling Airflow (CFM) and Power (Watts) vs. External Static Pressure with Filter (iwc)										
Cooling	Unit Outdoor	Airflow Setting (CFM/ton)		External Static Pressure						
				0.1	0.3	0.5	0.7	0.9		
Cooling	1.5 Ton	Cooling 450	CFM	672	674	672	666	656		
			CFM/Ton	Watts	48	84	122	161	203	
		Cooling 420	CFM	626	628	627	622	612		
			CFM/Ton	Watts	41	76	112	150	190	
		Cooling 400	CFM	595	598	597	592	583		
			CFM/Ton	Watts	37	70	105	143	182	
		Cooling 370	CFM	549	553	552	547	538		
			CFM/Ton	Watts	32	63	97	133	171	
		Cooling 350	CFM	518	522	522	518	509		
			CFM/Ton	Watts	29	59	91	126	164	
		Cooling 330	CFM	487	492	492	488	479		
			CFM/Ton	Watts	26	55	86	121	158	
		Cooling 310	CFM	456	461	462	458	449		
			CFM/Ton	Watts	23	51	81	115	153	
		Cooling 290	CFM	425	431	432	428	420		
			CFM/Ton	Watts	21	47	77	111	148	
		Cooling	2.0 Ton	Cooling 450	CFM	894	891	882	871	873
					CFM/Ton	Watts	91	137	182	228
Cooling 420	CFM			838	839	835	827	816		
	CFM/Ton			Watts	78	122	166	212	259	
Cooling 400	CFM			798	799	795	788	778		
	CFM/Ton			Watts	70	112	155	199	244	
Cooling 370	CFM			737	739	736	730	719		
	CFM/Ton			Watts	58	98	138	180	223	
Cooling 350	CFM			697	699	697	690	680		
	CFM/Ton			Watts	52	89	128	168	211	
Cooling 330	CFM			656	659	657	651	641		
	CFM/Ton			Watts	46	81	118	157	199	
Cooling 310	CFM			616	618	617	612	602		
	CFM/Ton			Watts	40	74	110	147	187	
Cooling 290	CFM			575	578	577	572	563		
	CFM/Ton			Watts	35	67	101	138	177	



Heating and Cooling Airflow Tables

Table 6. S9V2B060D3PSC Cooling Airflow (continued)

S9V2B060D3PSC Furnace Cooling Airflow (CFM) and Power (Watts) vs. External Static Pressure with Filter (iwc)								
Cooling	Unit Outdoor	Airflow Setting (CFM/ton)	External Static Pressure					
			0.1	0.3	0.5	0.7	0.9	
Cooling	2.5 Ton	Cooling 450 CFM/Ton	CFM	1120	1117	1111	1102	1089
			Watts	162	218	275	332	390
		Cooling 420 CFM/Ton	CFM	1037	1035	1029	1020	1008
			Watts	132	185	238	291	346
		Cooling 400 CFM/Ton	CFM	997	996	991	982	970
			Watts	120	171	222	274	327
		Cooling 370 CFM/Ton	CFM	923	923	918	910	898
			Watts	99	146	194	243	293
		Cooling 350 CFM/Ton	CFM	873	873	869	861	850
			Watts	86	132	177	224	273
		Cooling 330 CFM/Ton	CFM	823	824	820	813	802
			Watts	75	118	162	207	253
		Cooling 310 CFM/Ton	CFM	773	774	771	764	754
			Watts	65	106	147	191	235
Cooling	3.0 Ton (a)	Cooling 450 CFM/Ton	CFM	1336	1332	1324	1313	1299
			Watts	263	329	395	462	529
		Cooling 420 CFM/Ton	CFM	1250	1247	1239	1229	1216
			Watts	218	280	343	406	470
		Cooling 400 CFM/Ton	CFM	1193	1189	1183	1173	1159
			Watts	191	251	311	372	433
		Cooling 370 CFM/Ton	CFM	1105	1103	1097	1087	1075
			Watts	156	212	268	325	382
		Cooling 350 CFM/Ton (a)	CFM	1046	1045	1039	1030	1018
			Watts	135	189	242	296	351
		Cooling 330 CFM/Ton	CFM	987	986	981	973	961
			Watts	117	167	218	270	322
		Cooling 310 CFM/Ton	CFM	928	927	923	915	903
			Watts	100	148	196	245	295
Cooling 290 CFM/Ton	CFM	868	868	864	857	845		
	Watts	85	130	176	223	271		

(a) Factory Setting.

Table 7. S9V2B060U4PSC Heating Airflow

S9V2B060U4PSC Furnace Heating Airflow (CFM), Temp. Rise (°F), and Power (Watts) vs. External Static Pressure with Filter (iwc)								
				1st Stage Capacity = 38,100 2nd Stage Capacity = 58,400				
Heating	Airflow Setting	Target Airflow	External Static Pressure					
			0.1	0.3	0.5	0.7	0.9	
Heating 1st Stage	Low	782	CFM	776	769	762	756	749
			Temp. Rise	45	45	45	45	46
			Watts	70	109	149	188	227
	Medium Low	861	CFM	842	823	805	786	768
			Temp. Rise	42	43	43	44	44
			Watts	88	126	164	202	240
	Medium (a)	916	CFM	863	860	858	855	853
			Temp. Rise	41	41	41	41	41
			Watts	105	143	181	219	257
	High	1027	CFM	1105	1084	1063	1042	1021
			Temp. Rise	32	32	33	34	34
			Watts	135	173	210	248	285
Heating 2nd Stage	Low	990	CFM	1002	996	990	984	979
			Temp. Rise	55	55	55	55	55
			Watts	126	172	219	266	313
	Medium Low	1090	CFM	1130	1117	1105	1092	1079
			Temp. Rise	49	49	49	50	50
			Watts	160	206	253	300	347
	Medium (a)	1160	CFM	1139	1133	1128	1122	1116
			Temp. Rise	48	48	49	49	49
			Watts	181	231	281	331	381
	High	1300	CFM	1319	1307	1295	1283	1272
			Temp. Rise	41	42	42	42	43
			Watts	246	300	353	407	461

(a) Factory Setting.

Heating and Cooling Airflow Tables

Table 8. S9V2B060U4PSC Cooling Airflow

S9V2B060U4PSC Furnace Cooling Airflow (CFM) and Power (Watts) vs. External Static Pressure with Filter (iwc)								
Cooling	Unit Outdoor	Airflow Setting (CFM/ton)	External Static Pressure					
				0.1	0.3	0.5	0.7	0.9
Cooling	1.5 Ton	Cooling 450	CFM	663	673	666	641	596
		CFM/Ton	Watts	47	83	119	155	192
		Cooling 420	CFM	621	630	621	595	549
		CFM/Ton	Watts	41	75	109	144	180
		Cooling 400	CFM	582	580	566	528	507
		CFM/Ton	Watts	36	67	99	130	170
		Cooling 370	CFM	549	556	546	517	469
		CFM/Ton	Watts	32	63	95	128	162
		Cooling 350	CFM	521	527	516	486	437
		CFM/Ton	Watts	29	59	90	122	156
		Cooling 330	CFM	492	497	486	455	405
		CFM/Ton	Watts	26	55	85	117	150
		Cooling 310	CFM	463	468	455	423	372
		CFM/Ton	Watts	23	51	81	112	145
Cooling 290	CFM	435	438	424	391	339		
CFM/Ton	Watts	21	48	77	107	141		
Cooling	2.0 Ton	Cooling 450	CFM	878	893	890	869	829
		CFM/Ton	Watts	90	135	179	223	266
		Cooling 420	CFM	821	834	830	808	767
		CFM/Ton	Watts	76	119	161	202	244
		Cooling 400	CFM	770	778	770	742	725
		CFM/Ton	Watts	66	105	144	182	230
		Cooling 370	CFM	725	737	731	707	664
		CFM/Ton	Watts	57	96	134	172	211
		Cooling 350	CFM	687	698	691	666	622
		CFM/Ton	Watts	51	88	124	161	199
		Cooling 330	CFM	649	659	651	625	580
		CFM/Ton	Watts	45	80	115	151	188
		Cooling 310	CFM	611	620	611	584	538
		CFM/Ton	Watts	39	73	107	142	177
Cooling 290	CFM	573	581	571	543	496		
CFM/Ton	Watts	34	67	99	133	168		
Cooling	2.5 Ton	Cooling 450	CFM	1097	1114	1114	1097	1061
		CFM/Ton	Watts	159	212	265	317	368
		Cooling 420	CFM	1023	1040	1039	1020	984
		CFM/Ton	Watts	133	184	233	282	331
		Cooling 400	CFM	976	989	990	970	932
		CFM/Ton	Watts	117	166	214	261	308
		Cooling 370	CFM	902	917	915	894	855
		CFM/Ton	Watts	97	142	187	232	276
		Cooling 350	CFM	854	868	865	843	803
		CFM/Ton	Watts	84	128	171	214	257
		Cooling 330	CFM	806	819	815	793	752
		CFM/Ton	Watts	73	115	157	198	239
		Cooling 310	CFM	759	771	766	742	700
		CFM/Ton	Watts	63	103	143	182	222
Cooling 290	CFM	711	722	716	692	648		
CFM/Ton	Watts	55	93	130	168	206		
Cooling	3.0 Ton	Cooling 450	CFM	1319	1340	1343	1328	1295
		CFM/Ton	Watts	260	321	382	441	501
		Cooling 420	CFM	1229	1249	1251	1235	1201
		CFM/Ton	Watts	215	274	331	387	443
		Cooling 400	CFM	1170	1189	1190	1173	1139
		CFM/Ton	Watts	189	245	300	354	408
		Cooling 370	CFM	1082	1100	1099	1081	1046
		CFM/Ton	Watts	154	206	258	309	360
		Cooling 350	CFM	1023	1040	1039	1020	984
		CFM/Ton	Watts	133	184	233	282	331
		Cooling 330	CFM	965	981	979	960	922
		CFM/Ton	Watts	114	163	210	257	304
		Cooling 310	CFM	907	922	919	899	860
		CFM/Ton	Watts	98	144	189	234	278
Cooling 290	CFM	850	863	860	838	798		
CFM/Ton	Watts	83	127	170	212	255		



Heating and Cooling Airflow Tables

Table 8. S9V2B060U4PSC Cooling Airflow (continued)

S9V2B060U4PSC Furnace Cooling Airflow (CFM) and Power (Watts) vs. External Static Pressure with Filter (iwc)								
Cooling	Unit Outdoor	Airflow Setting (CFM/ton)	External Static Pressure					
			0.1	0.3	0.5	0.7	0.9	
Cooling	3.5 Ton	Cooling 450 CFM/Ton	CFM	1546	1570	1576	1564	1534
		Watts	399	469	537	604	671	
		Cooling 420 CFM/Ton	CFM	1440	1462	1466	1453	1422
		Watts	329	395	459	523	586	
		Cooling 400 CFM/Ton	CFM	1369	1391	1394	1380	1348
		Watts	287	350	413	474	535	
		Cooling 370 CFM/Ton	CFM	1264	1284	1287	1271	1238
		Watts	232	291	350	408	465	
		Cooling 350 CFM/Ton	CFM	1195	1214	1215	1199	1165
		Watts	199	257	313	368	423	
		Cooling 330 CFM/Ton	CFM	1126	1144	1145	1127	1092
		Watts	170	225	278	331	384	
		Cooling 310 CFM/Ton	CFM	1059	1075	1074	1056	1020
		Watts	145	197	248	298	348	
Cooling 290 CFM/Ton	CFM	992	1006	1004	985	948		
Watts	122	171	219	267	315			
Cooling	4.0 Ton (a)	Cooling 450 CFM/Ton	CFM	1779	1806	1814	1805	1778
		Watts	585	661	737	812	886	
		Cooling 420 CFM/Ton	CFM	1654	1679	1686	1676	1647
		Watts	480	552	624	695	765	
		Cooling 400 CFM/Ton	CFM	1572	1596	1602	1590	1561
		Watts	418	488	557	625	693	
		Cooling 370 CFM/Ton	CFM	1450	1472	1477	1464	1433
		Watts	335	401	466	530	594	
		Cooling 350 CFM/Ton (a)	CFM	1369	1391	1394	1380	1348
		Watts	287	350	413	474	535	
		Cooling 330 CFM/Ton	CFM	1289	1310	1312	1297	1264
		Watts	244	305	364	423	481	
		Cooling 310 CFM/Ton	CFM	1210	1229	1231	1214	1180
		Watts	206	264	320	376	431	
Cooling 290 CFM/Ton	CFM	1131	1149	1150	1132	1097		
Watts	172	227	281	334	386			

(a) Factory Setting.

Table 9. S9V2B080U4PSC Heating Airflow

S9V2B080U4PSC Furnace Heating Airflow (CFM), Temp. Rise (°F), and Power (Watts) vs. External Static Pressure with Filter (iwc)								
			1st Stage Capacity = 50,500 2nd Stage Capacity = 77,700					
Heating	Airflow Setting	Target Airflow	External Static Pressure					
			0.1	0.3	0.5	0.7	0.9	
Heating 1st Stage	Low	864	CFM	914	882	849	816	783
			Temp. Rise	51	53	55	57	59
			Watts	90	131	172	213	255
	Medium Low (a)	907	CFM	940	912	885	858	831
			Temp. Rise	50	51	53	54	56
			Watts	104	141	178	215	253
	Medium	958	CFM	983	932	881	830	779
			Temp. Rise	47	50	53	55	58
			Watts	118	151	184	218	251
	High	1051	CFM	1029	1068	1107	1146	1185
			Temp. Rise	45	44	42	40	39
			Watts	155	195	235	275	314
Heating 2nd Stage	Low	1200	CFM	1207	1206	1205	1204	1203
			Temp. Rise	60	60	60	60	60
			Watts	206	258	309	361	412
	Medium Low (a)	1260	CFM	1260	1261	1262	1263	1264
			Temp. Rise	57	57	57	57	57
			Watts	232	287	342	397	452
	Medium	1330	CFM	1360	1347	1333	1320	1306
			Temp. Rise	53	53	54	54	55
			Watts	263	322	380	439	497
	High	1460	CFM	1420	1439	1458	1477	1496
			Temp. Rise	51	50	49	49	48
			Watts	377	433	489	546	602

(a) Factory Setting.

Heating and Cooling Airflow Tables

Table 10. S9V2B080D4PSC Heating Airflow

S9V2B080D4PSC Furnace Heating Airflow (CFM), Temp. Rise (°F), and Power (Watts) vs. External Static Pressure with Filter (iwc)								
				1st Stage Capacity = 50,300 2nd Stage Capacity = 77,350				
Heating	Airflow Setting	Target Airflow		External Static Pressure				
				0.1	0.3	0.5	0.7	0.9
Heating 1st Stage	Low	864	CFM	808	795	782	770	757
			Temp. Rise	58	59	60	61	62
			Watts	82	126	171	216	261
	Medium Low	907	CFM	836	823	810	797	784
			Temp. Rise	56	57	58	59	60
			Watts	94	137	180	223	266
	Medium (a)	958	CFM	896	881	866	851	836
			Temp. Rise	51	53	54	56	57
			Watts	110	153	196	238	281
	High	1066	CFM	977	963	949	934	920
			Temp. Rise	48	49	50	51	52
			Watts	128	179	230	281	332
Heating 2nd Stage	Low	1200	CFM	1125	1104	1082	1061	1039
			Temp. Rise	64	65	67	68	69
			Watts	191	241	292	342	392
	Medium Low	1260	CFM	1188	1162	1135	1109	1082
			Temp. Rise	61	62	64	65	66
			Watts	219	273	326	380	434
	Medium (a)	1330	CFM	1243	1220	1197	1174	1151
			Temp. Rise	58	59	60	61	62
			Watts	259	309	360	410	461
	High	1480	CFM	1342	1328	1313	1299	1284
			Temp. Rise	53	54	55	56	56
			Watts	329	389	448	508	567

(a) Factory Setting.

Table 11. S9V2B080U4PSC / S9V2B080D4PSC Cooling Airflow

S9V2B080U4PSC / S9V2B080D4PSC Furnace Cooling Airflow (CFM) and Power (Watts) vs. External Static Pressure with Filter								
Cooling	Unit Outdoor	Airflow Setting (CFM/ton)		External Static Pressure				
				0.1	0.3	0.5	0.7	0.9
Cooling	2.0 Ton	Cooling 450 CFM/Ton	CFM	892	899	893	872	838
			Watts	91	136	180	222	265
		Cooling 420 CFM/Ton	CFM	834	841	834	813	777
			Watts	77	120	161	202	243
		Cooling 400 CFM/Ton	CFM	785	785	781	754	737
			Watts	67	106	146	183	229
		Cooling 370 CFM/Ton	CFM	738	744	736	714	677
			Watts	58	97	134	172	210
		Cooling 350 CFM/Ton	CFM	700	705	697	675	638
			Watts	52	89	125	161	198
		Cooling 330 CFM/Ton	CFM	662	666	658	635	598
			Watts	46	81	116	151	187
		Cooling 310 CFM/Ton	CFM	624	627	619	596	558
			Watts	40	74	107	142	177
Cooling 290 CFM/Ton	CFM	585	588	580	557	518		
	Watts	35	67	100	133	168		
Cooling	2.5 Ton	Cooling 450 CFM/Ton	CFM	1108	1120	1116	1098	1065
			Watts	159	213	265	315	365
		Cooling 420 CFM/Ton	CFM	1035	1046	1041	1022	989
			Watts	133	184	233	281	328
		Cooling 400 CFM/Ton	CFM	988	997	992	972	938
			Watts	118	167	214	260	306
		Cooling 370 CFM/Ton	CFM	916	924	918	897	863
			Watts	97	143	188	231	275
		Cooling 350 CFM/Ton	CFM	868	875	868	848	813
			Watts	85	129	172	213	255
		Cooling 330 CFM/Ton	CFM	820	826	819	798	762
			Watts	74	116	157	197	237
		Cooling 310 CFM/Ton	CFM	772	778	770	749	712
			Watts	64	104	143	182	221
Cooling 290 CFM/Ton	CFM	724	729	721	699	663		
	Watts	56	94	131	168	205		



Heating and Cooling Airflow Tables

Table 11. S9V2B080U4PSC / S9V2B080D4PSC Cooling Airflow (continued)

S9V2B080U4PSC / S9V2B080D4PSC Furnace Cooling Airflow (CFM) and Power (Watts) vs. External Static Pressure with Filter								
Cooling	Unit Outdoor	Airflow Setting (CFM/ton)		External Static Pressure				
				0.1	0.3	0.5	0.7	0.9
Cooling	3.0 Ton	Cooling 450	CFM	1326	1341	1341	1325	1296
		CFM/Ton	Watts	257	320	380	439	497
		Cooling 420	CFM	1239	1252	1250	1234	1203
		CFM/Ton	Watts	214	273	330	385	440
		Cooling 400	CFM	1181	1193	1191	1173	1142
		CFM/Ton	Watts	188	245	299	353	405
		Cooling 370	CFM	1094	1105	1101	1083	1050
		CFM/Ton	Watts	153	207	258	308	358
		Cooling 350	CFM	1036	1046	1041	1022	989
		CFM/Ton	Watts	133	184	233	281	329
		Cooling 330	CFM	978	987	982	962	928
		CFM/Ton	Watts	115	164	210	256	302
Cooling 310	CFM	920	929	923	902	868		
CFM/Ton	Watts	99	145	189	233	277		
Cooling 290	CFM	863	870	863	843	807		
CFM/Ton	Watts	84	128	170	212	253		
Cooling	3.5 Ton	Cooling 450	CFM	1547	1565	1568	1556	1529
		CFM/Ton	Watts	392	463	531	598	664
		Cooling 420	CFM	1443	1460	1462	1448	1420
		CFM/Ton	Watts	324	391	456	519	581
		Cooling 400	CFM	1375	1391	1391	1376	1347
		CFM/Ton	Watts	284	348	410	471	530
		Cooling 370	CFM	1273	1287	1286	1269	1239
		CFM/Ton	Watts	230	290	349	405	461
		Cooling 350	CFM	1205	1218	1215	1199	1167
		CFM/Ton	Watts	198	256	312	366	420
		Cooling 330	CFM	1137	1149	1146	1128	1096
		CFM/Ton	Watts	170	225	278	330	381
Cooling 310	CFM	1069	1080	1076	1057	1024		
CFM/Ton	Watts	145	197	248	297	345		
Cooling 290	CFM	1002	1012	1007	987	954		
CFM/Ton	Watts	122	172	220	266	313		
Cooling	4.0 Ton (a)	Cooling 450	CFM	1769	1791	1797	1789	1766
		CFM/Ton	Watts	570	648	725	799	873
		Cooling 420	CFM	1650	1670	1675	1664	1639
		CFM/Ton	Watts	469	544	616	686	756
		Cooling 400	CFM	1571	1590	1593	1582	1555
		CFM/Ton	Watts	410	481	550	618	685
		Cooling 370	CFM	1453	1470	1472	1458	1430
		CFM/Ton	Watts	330	397	462	526	588
		Cooling 350	CFM	1375	1391	1391	1376	1347
		CFM/Ton (a)	Watts	284	348	410	471	530
		Cooling 330	CFM	1297	1312	1311	1295	1265
		CFM/Ton	Watts	242	303	363	420	477
Cooling 310	CFM	1219	1233	1230	1214	1183		
CFM/Ton	Watts	205	263	319	374	428		
Cooling 290	CFM	1142	1154	1151	1133	1101		
CFM/Ton	Watts	172	227	280	332	384		

(a) Factory Setting.

Heating and Cooling Airflow Tables

Table 12. S9V2C080U5PSC Heating Airflow

S9V2C080U5PSC Furnace Heating Airflow (CFM), Temp. Rise (°F), and Power (Watts) vs. External Static Pressure with Filter (iwc)								
				1st Stage Capacity = 50,600 2nd Stage Capacity = 77,750				
Heating	Airflow Setting	Target Airflow		External Static Pressure				
				0.1	0.3	0.5	0.7	0.9
Heating 1st Stage	Low	857	CFM	838	821	804	788	771
			Temp. Rise	56	57	57	58	59
			Watts	68	109	151	192	234
	Medium Low ^(a)	1044	CFM	967	993	1019	1045	1070
			Temp. Rise	48	47	46	45	44
			Watts	91	145	198	252	306
	Medium	1123	CFM	1060	1058	1056	1053	1051
			Temp. Rise	44	44	44	43	43
			Watts	108	165	222	279	335
	High	1224	CFM	1266	1171	1075	980	884
			Temp. Rise	36	40	43	46	50
			Watts	134	194	253	313	373
Heating 2nd Stage	Low	1190	CFM	1114	1127	1141	1154	1167
			Temp. Rise	64	63	62	62	61
			Watts	127	188	250	312	373
	Medium Low ^(a)	1450	CFM	1359	1378	1396	1414	1432
			Temp. Rise	52	52	51	50	49
			Watts	216	291	365	439	514
	Medium	1560	CFM	1466	1474	1482	1490	1497
			Temp. Rise	48	48	48	48	48
			Watts	263	344	426	507	588
	High	1700	CFM	1774	1731	1689	1647	1605
			Temp. Rise	40	41	42	43	44
			Watts	356	437	518	600	681

^(a) Factory Setting.

Table 13. S9V2C080U5PSC Cooling Airflow

S9V2C080U5PSC Furnace Cooling Airflow (CFM) and Power (Watts) vs. External Static Pressure with Filter (iwc)								
Cooling	Unit Outdoor	Airflow Setting (CFM/ton)		External Static Pressure				
				0.1	0.3	0.5	0.7	0.9
Cooling	3.0 Ton	Cooling 450 CFM/Ton	CFM	1335	1347	1356	1362	1366
			Watts	182	241	303	366	431
		Cooling 420 CFM/Ton	CFM	1246	1259	1267	1273	1277
			Watts	152	208	266	326	387
		Cooling 400 CFM/Ton	CFM	1188	1200	1208	1214	1217
			Watts	134	188	243	301	360
		Cooling 370 CFM/Ton	CFM	1100	1111	1118	1123	1125
			Watts	110	160	212	266	322
		Cooling 350 CFM/Ton	CFM	1041	1052	1058	1061	1063
			Watts	96	143	193	245	299
		Cooling 330 CFM/Ton	CFM	983	993	997	999	1000
			Watts	83	128	176	225	277
		Cooling 310 CFM/Ton	CFM	925	933	936	937	936
			Watts	72	114	159	207	257
		Cooling 290 CFM/Ton	CFM	867	873	874	873	871
			Watts	61	101	144	190	239
Cooling	3.5 Ton	Cooling 450 CFM/Ton	CFM	1557	1568	1576	1581	1585
			Watts	273	342	413	486	559
		Cooling 420 CFM/Ton	CFM	1453	1465	1473	1480	1483
			Watts	228	292	359	427	496
		Cooling 400 CFM/Ton	CFM	1384	1396	1405	1411	1415
			Watts	200	262	325	391	457
		Cooling 370 CFM/Ton	CFM	1281	1293	1302	1308	1312
			Watts	163	221	280	341	404
		Cooling 350 CFM/Ton	CFM	1212	1224	1233	1239	1242
			Watts	142	196	253	311	371
		Cooling 330 CFM/Ton	CFM	1144	1155	1163	1168	1171
			Watts	122	173	227	283	341
		Cooling 310 CFM/Ton	CFM	1076	1086	1093	1097	1099
			Watts	104	153	204	257	312
		Cooling 290 CFM/Ton	CFM	1007	1017	1023	1025	1026
			Watts	88	134	183	233	286



Heating and Cooling Airflow Tables

Table 13. S9V2C080U5PSC Cooling Airflow (continued)

S9V2C080U5PSC Furnace Cooling Airflow (CFM) and Power (Watts) vs. External Static Pressure with Filter (iwc)								
Cooling	Unit Outdoor	Airflow Setting (CFM/ton)	External Static Pressure					
			0.1	0.3	0.5	0.7	0.9	
Cooling	4.0 Ton	Cooling 450	CFM	1782	1789	1794	1797	1798
		CFM/Ton	Watts	392	471	551	632	715
		Cooling 420	CFM	1662	1671	1678	1682	1685
		CFM/Ton	Watts	325	399	474	550	628
		Cooling 400	CFM	1582	1592	1600	1606	1609
		CFM/Ton	Watts	285	355	427	500	575
		Cooling 370	CFM	1463	1474	1483	1489	1493
		CFM/Ton	Watts	232	297	364	432	502
		Cooling 350	CFM	1384	1396	1405	1411	1415
		CFM/Ton	Watts	200	262	325	391	457
		Cooling 330	CFM	1305	1317	1327	1333	1337
		CFM/Ton	Watts	172	230	290	352	416
		Cooling 310	CFM	1227	1239	1248	1254	1257
		CFM/Ton	Watts	146	201	258	317	378
Cooling	4.5 Ton	Cooling 290	CFM	1149	1160	1168	1173	1176
		CFM/Ton	Watts	123	175	229	285	343
		Cooling 450	CFM	2008	2011	2012	2011	2008
		CFM/Ton	Watts	542	630	719	811	903
		Cooling 420	CFM	1872	1878	1881	1883	1882
		CFM/Ton	Watts	448	530	614	700	786
		Cooling 400	CFM	1782	1789	1794	1797	1798
		CFM/Ton	Watts	392	471	551	632	715
		Cooling 370	CFM	1647	1656	1663	1668	1670
		CFM/Ton	Watts	318	390	465	541	618
		Cooling 350	CFM	1557	1568	1576	1581	1585
		CFM/Ton	Watts	273	342	413	486	559
		Cooling 330	CFM	1468	1479	1488	1494	1498
		CFM/Ton	Watts	234	299	366	435	505
Cooling	5.0 Ton ^(a)	Cooling 310	CFM	1379	1391	1400	1407	1410
		CFM/Ton	Watts	198	260	323	388	455
		Cooling 290	CFM	1291	1303	1312	1318	1322
		CFM/Ton	Watts	167	224	284	346	409
		Cooling 450	CFM	2235	2233	2230	2224	2216
		CFM/Ton	Watts	726	824	923	1023	1125
		Cooling 420	CFM	2084	2085	2084	2082	2078
		CFM/Ton	Watts	599	690	783	877	973
		Cooling 400	CFM	1983	1986	1988	1988	1985
		CFM/Ton	Watts	524	611	699	789	880
		Cooling 370	CFM	1832	1838	1843	1845	1845
		CFM/Ton	Watts	423	503	586	669	754
		Cooling 350	CFM	1732	1740	1746	1749	1751
		CFM/Ton ^(a)	Watts	363	440	518	597	678
Cooling 330	CFM	1632	1641	1649	1654	1656		
CFM/Ton	Watts	310	382	456	531	608		
Cooling 310	CFM	1533	1543	1551	1557	1561		
CFM/Ton	Watts	262	330	400	471	544		
Cooling 290	CFM	1434	1445	1454	1460	1464		
CFM/Ton	Watts	219	283	349	416	485		

^(a) Factory Setting.

Heating and Cooling Airflow Tables

Table 14. S9V2C100U5PSC Heating Airflow

S9V2C100U5PSC Furnace Heating Airflow (CFM), Temp. Rise (°F), and Power (Watts) vs. External Static Pressure with Filter (iwc)								
				1st Stage Capacity = 63,400 2nd Stage Capacity = 97,650				
Heating	Airflow Setting	Target Airflow		External Static Pressure				
				0.1	0.3	0.5	0.7	0.9
Heating 1st Stage	Low	1145	CFM	1111	1097	1083	1068	1054
			Temp. Rise	52	52	52	52	53
			Watts	135	184	234	283	333
	Medium Low	1426	CFM	1393	1383	1372	1362	1352
			Temp. Rise	41	41	42	42	42
			Watts	232	286	340	394	447
	Medium ^(a)	1483	CFM	1451	1447	1443	1438	1434
			Temp. Rise	39	40	40	40	40
			Watts	260	310	360	410	460
	High	1548	CFM	1495	1477	1458	1439	1421
			Temp. Rise	38	39	39	40	40
			Watts	285	352	419	486	553
Heating 2nd Stage	Low	1590	CFM	1564	1550	1536	1522	1508
			Temp. Rise	58	58	58	58	59
			Watts	323	397	470	544	618
	Medium Low	1980	CFM	1959	1936	1913	1891	1868
			Temp. Rise	46	46	47	47	47
			Watts	597	681	764	847	930
	Medium ^(a)	2060	CFM	2047	2034	2021	2008	1995
			Temp. Rise	44	44	44	45	45
			Watts	655	737	818	900	982
	High	2150	CFM	2102	2087	2073	2058	2044
			Temp. Rise	43	43	43	44	44
			Watts	745	801	857	913	969

^(a) Factory Setting.

Table 15. S9V2C100D5PSC Heating Airflow

S9V2C100D5PSC Furnace Heating Airflow (CFM), Temp. Rise (°F), and Power (Watts) vs. External Static Pressure with Filter (iwc)								
				1st Stage Capacity = 63,300 2nd Stage Capacity = 97,150				
Heating	Airflow Setting	Target Airflow		External Static Pressure				
				0.1	0.3	0.5	0.7	0.9
Heating 1st Stage	Low	1094	CFM	1093	1092	1090	1089	1088
			Temp. Rise	53	53	53	52	52
			Watts	126	183	240	296	353
	Medium Low	1296	CFM	1234	1238	1242	1247	1251
			Temp. Rise	47	47	47	47	47
			Watts	186	243	299	356	413
	Medium ^(a)	1346	CFM	1279	1268	1256	1245	1234
			Temp. Rise	45	45	46	46	47
			Watts	214	268	321	375	428
	High	1512	CFM	1453	1429	1405	1381	1358
			Temp. Rise	40	40	41	41	42
			Watts	277	344	411	478	545
Heating 2nd Stage	Low	1520	CFM	1484	1477	1469	1461	1453
			Temp. Rise	60	60	61	61	61
			Watts	296	370	444	518	592
	Medium Low	1800	CFM	1693	1688	1684	1679	1674
			Temp. Rise	53	53	53	53	53
			Watts	449	533	618	702	786
	Medium ^(a)	1870	CFM	1768	1772	1775	1778	1781
			Temp. Rise	51	50	50	50	50
			Watts	505	591	678	765	852
	High	2100	CFM	1969	1956	1944	1931	1918
			Temp. Rise	45	45	46	46	46
			Watts	723	789	854	920	986

^(a) Factory Setting.



Heating and Cooling Airflow Tables

Table 16. S9V2C100U5PSC / S9V2C100D5PSC Cooling Airflow

S9V2C100U5PSC / S9V2C100D5PSC Furnace Cooling Airflow (CFM) and Power (Watts) vs. External Static Pressure with Filter (iwc)								
Cooling	Unit Outdoor	Airflow Setting (CFM/ton)		External Static Pressure				
				0.1	0.3	0.5	0.7	0.9
Cooling	2.5 Ton	Cooling 450	CFM	1153	1149	1147	1145	1141
		CFM/Ton	Watts	111	159	208	260	314
		Cooling 420	CFM	1077	1073	1071	1068	1064
		CFM/Ton	Watts	94	138	185	235	287
		Cooling 400	CFM	1061	1057	1054	1044	1021
		CFM/Ton	Watts	90	134	180	227	273
		Cooling 370	CFM	950	945	942	939	935
		CFM/Ton	Watts	69	109	151	197	246
		Cooling 350	CFM	899	893	890	887	882
		CFM/Ton	Watts	60	98	140	184	232
		Cooling 330	CFM	848	841	838	835	830
		CFM/Ton	Watts	53	89	129	172	219
Cooling	3.0 Ton	Cooling 310	CFM	796	789	786	782	777
		CFM/Ton	Watts	46	80	119	161	208
		Cooling 290	CFM	745	737	733	729	724
		CFM/Ton	Watts	39	72	110	151	198
		Cooling 450	CFM	1378	1376	1374	1372	1368
		CFM/Ton	Watts	178	234	292	352	413
		Cooling 420	CFM	1289	1286	1284	1282	1277
		CFM/Ton	Watts	149	201	256	312	371
		Cooling 400	CFM	1228	1225	1223	1221	1217
		CFM/Ton	Watts	131	181	234	288	345
		Cooling 370	CFM	1138	1134	1132	1130	1125
		CFM/Ton	Watts	108	154	203	255	309
Cooling	3.5 Ton	Cooling 350	CFM	1077	1073	1071	1068	1064
		CFM/Ton	Watts	94	138	185	235	287
		Cooling 330	CFM	1016	1011	1009	1006	1002
		CFM/Ton	Watts	81	123	168	216	266
		Cooling 310	CFM	955	950	947	944	940
		CFM/Ton	Watts	70	110	153	199	248
		Cooling 290	CFM	894	888	885	882	877
		CFM/Ton	Watts	59	97	138	183	231
		Cooling 450	CFM	1601	1599	1597	1594	1590
		CFM/Ton	Watts	269	334	401	469	539
		Cooling 420	CFM	1498	1496	1494	1491	1487
		CFM/Ton	Watts	224	284	347	411	477
Cooling	4.0 Ton	Cooling 400	CFM	1428	1426	1424	1422	1417
		CFM/Ton	Watts	196	254	314	376	439
		Cooling 370	CFM	1324	1321	1319	1317	1313
		CFM/Ton	Watts	160	214	270	327	387
		Cooling 350	CFM	1253	1251	1249	1246	1242
		CFM/Ton	Watts	138	190	243	298	355
		Cooling 330	CFM	1183	1180	1178	1175	1171
		CFM/Ton	Watts	119	167	218	271	326
		Cooling 310	CFM	1112	1109	1107	1104	1100
		CFM/Ton	Watts	102	147	196	246	299
		Cooling 290	CFM	1041	1037	1035	1032	1028
		CFM/Ton	Watts	86	129	175	223	275
Cooling	4.0 Ton	Cooling 450	CFM	1820	1819	1816	1812	1807
		CFM/Ton	Watts	388	462	538	615	693
		Cooling 420	CFM	1704	1702	1700	1697	1692
		CFM/Ton	Watts	321	390	461	533	607
		Cooling 400	CFM	1626	1624	1622	1619	1614
		CFM/Ton	Watts	281	347	415	484	554
		Cooling 370	CFM	1507	1505	1504	1501	1497
		CFM/Ton	Watts	228	289	352	417	482
		Cooling 350	CFM	1428	1426	1424	1422	1417
		CFM/Ton	Watts	196	254	314	376	439
		Cooling 330	CFM	1348	1346	1344	1342	1338
		CFM/Ton	Watts	168	223	280	338	399
Cooling 310	CFM	1268	1266	1264	1261	1257		
CFM/Ton	Watts	143	195	248	304	362		
Cooling 290	CFM	1188	1185	1183	1180	1176		
CFM/Ton	Watts	120	169	220	273	328		

Heating and Cooling Airflow Tables

Table 16. S9V2C100U5PSC / S9V2C100D5PSC Cooling Airflow (continued)

S9V2C100U5PSC / S9V2C100D5PSC Furnace Cooling Airflow (CFM) and Power (Watts) vs. External Static Pressure with Filter (iwc)								
Cooling	Unit Outdoor	Airflow Setting (CFM/ton)		External Static Pressure				
				0.1	0.3	0.5	0.7	0.9
Cooling	4.5 Ton	Cooling 450	CFM	2037	2034	2031	2026	2020
			Watts	537	621	706	792	879
		Cooling 420	CFM	1907	1905	1902	1898	1893
			Watts	444	522	601	682	763
		Cooling 400	CFM	1820	1819	1816	1812	1807
			Watts	388	462	538	615	693
		Cooling 370	CFM	1689	1687	1685	1682	1677
			Watts	313	382	452	524	597
		Cooling 350	CFM	1601	1599	1597	1594	1590
			Watts	269	334	401	469	539
		Cooling 330	CFM	1512	1510	1509	1506	1501
			Watts	230	291	354	419	485
Cooling 310	CFM	1423	1421	1419	1417	1412		
	Watts	195	252	312	373	436		
Cooling 290	CFM	1334	1331	1329	1327	1323		
	Watts	163	217	274	332	392		
Cooling	5.0 Ton ^(a)	Cooling 450	CFM	2249	2246	2241	2236	2228
			Watts	722	815	909	1004	1101
		Cooling 420	CFM	2108	2105	2101	2096	2090
			Watts	595	681	770	859	949
		Cooling 400	CFM	2013	2010	2007	2003	1997
			Watts	519	602	685	771	857
		Cooling 370	CFM	1869	1867	1864	1860	1855
			Watts	418	494	572	651	731
		Cooling 350	CFM	1772	1770	1768	1764	1759
			Watts	359	431	505	580	656
		Cooling 330	CFM	1675	1673	1671	1667	1663
			Watts	305	374	443	514	587
Cooling 310	CFM	1576	1575	1573	1570	1565		
	Watts	258	322	388	455	523		
Cooling 290	CFM	1478	1476	1474	1471	1467		
	Watts	216	276	337	401	466		

^(a) Factory Setting.

Table 17. S9V2D120U5PSC Heating Airflow

S9V2D120U5PSC Furnace Heating Airflow (CFM), Temp. Rise (°F), and Power (Watts) vs. External Static Pressure with Filter (iwc)								
				1st Stage Capacity = 75,500 2nd Stage Capacity = 115,700				
Heating	Airflow Setting	Target Airflow		External Static Pressure				
				0.1	0.3	0.5	0.7	0.9
Heating 1st Stage	Low	1123	CFM	1138	1158	1178	1198	1218
			Temp. Rise	61	60	59	58	57
			Watts	115	176	236	297	358
	Medium Low	1332	CFM	1371	1383	1394	1406	1417
			Temp. Rise	51	50	50	49	49
			Watts	182	251	320	389	457
	Medium ^(a)	1404	CFM	1440	1450	1461	1471	1482
			Temp. Rise	48	48	48	47	47
			Watts	208	283	357	431	505
	High	1620	CFM	1669	1674	1680	1685	1691
			Temp. Rise	42	42	41	41	41
			Watts	315	388	460	533	605
Heating 2nd Stage	Low	1560	CFM	1654	1637	1621	1604	1587
			Temp. Rise	65	66	67	67	68
			Watts	291	360	430	499	568
	Medium Low	1850	CFM	1980	1951	1922	1893	1864
			Temp. Rise	55	56	57	58	58
			Watts	456	539	621	704	787
	Medium ^(a)	1950	CFM	2075	2037	1999	1961	1923
			Temp. Rise	52	53	54	55	56
			Watts	527	611	696	781	865
	High	2250	CFM	2280	2197	2114	2032	1949
			Temp. Rise	48	50	52	54	56
			Watts	795	819	842	865	888

^(a) Factory Setting.



Heating and Cooling Airflow Tables

Table 18. S9V2D120D5PSC Heating Airflow

S9V2D120D5PSC Furnace Heating Airflow (CFM), Temp. Rise (°F), and Power (Watts) vs. External Static Pressure with Filter (iwc)								
				1st Stage Capacity = 75,800 2nd Stage Capacity = 116,100				
Heating	Airflow Setting	Target Airflow		External Static Pressure				
				0.1	0.3	0.5	0.7	0.9
Heating 1st Stage	Low	1160	CFM	1234	1240	1246	1252	1258
			Temp. Rise	56	56	56	55	55
			Watts	137	198	258	319	380
	Medium Low	1332	CFM	1305	1311	1318	1325	1332
			Temp. Rise	53	53	53	52	52
			Watts	158	221	284	347	410
	Medium	1404	CFM	1324	1510	1697	1884	2070
			Temp. Rise	53	46	39	32	25
			Watts	179	246	313	380	447
	High ^(a)	1620	CFM	1598	1484	1371	1257	1144
			Temp. Rise	44	47	49	52	54
			Watts	266	316	366	416	466
Heating 2nd Stage	Low	1750	CFM	1687	1673	1659	1645	1631
			Temp. Rise	63	64	64	65	65
			Watts	327	407	487	568	648
	Medium Low	1850	CFM	1788	1771	1754	1738	1721
			Temp. Rise	60	60	61	61	62
			Watts	380	464	549	633	718
	Medium	1950	CFM	1891	1862	1833	1803	1774
			Temp. Rise	56	57	58	60	61
			Watts	424	524	624	724	824
	High ^(a)	2250	CFM	2080	2100	2120	2140	2160
			Temp. Rise	51	51	51	51	51
			Watts	708	768	828	888	948

^(a) Factory Setting.

Table 19. S9V2D120U5PSC / S9V2D120D5PSC Cooling Airflow

S9V2D120U5PSC / S9V2D120D5PSC Furnace Cooling Airflow (CFM) and Power (Watts) vs. External Static Pressure with Filter (iwc)								
Cooling	Unit Outdoor	Airflow Setting (CFM/ton)		External Static Pressure				
				0.1	0.3	0.5	0.7	0.9
Cooling	3.0 Ton	Cooling 450	CFM	1336	1346	1354	1360	1363
			Watts	163	221	281	341	402
		Cooling 420	CFM	1248	1258	1265	1271	1274
			Watts	137	191	247	304	361
		Cooling 400	CFM	1189	1199	1206	1211	1214
			Watts	121	173	227	281	336
		Cooling 370	CFM	1102	1110	1116	1121	1123
			Watts	100	148	198	249	301
		Cooling 350	CFM	1043	1051	1057	1060	1062
			Watts	87	133	181	230	279
		Cooling 330	CFM	985	991	996	999	1000
			Watts	76	119	165	211	259
		Cooling 310	CFM	927	932	936	937	938
			Watts	65	107	150	195	241
		Cooling 290	CFM	869	872	874	875	875
			Watts	56	95	136	179	223
Cooling	3.5 Ton	Cooling 450	CFM	1559	1567	1574	1579	1583
			Watts	244	312	381	450	519
		Cooling 420	CFM	1455	1464	1472	1477	1481
			Watts	204	267	331	396	462
		Cooling 400	CFM	1386	1395	1403	1409	1413
			Watts	179	240	301	363	426
		Cooling 370	CFM	1282	1292	1300	1305	1309
			Watts	147	203	260	318	376
		Cooling 350	CFM	1214	1223	1231	1236	1239
			Watts	127	181	235	290	346
		Cooling 330	CFM	1145	1154	1161	1166	1169
			Watts	110	160	212	265	318
		Cooling 310	CFM	1077	1085	1092	1096	1098
			Watts	94	142	191	241	292
		Cooling 290	CFM	1009	1016	1021	1025	1026
			Watts	80	125	171	219	267

Heating and Cooling Airflow Tables

Table 19. S9V2D120U5PSC / S9V2D120D5PSC Cooling Airflow (continued)

S9V2D120U5PSC / S9V2D120D5PSC Furnace Cooling Airflow (CFM) and Power (Watts) vs. External Static Pressure with Filter (iwc)								
Cooling	Unit Outdoor	Airflow Setting (CFM/ton)		External Static Pressure				
				0.1	0.3	0.5	0.7	0.9
Cooling	4.0 Ton	Cooling 450	CFM	1783	1789	1793	1796	1798
			Watts	350	427	505	584	663
		Cooling 420	CFM	1663	1671	1677	1681	1683
			Watts	290	362	436	509	583
		Cooling 400	CFM	1584	1592	1599	1603	1607
			Watts	255	324	393	464	534
		Cooling 370	CFM	1465	1474	1481	1487	1491
			Watts	207	271	336	401	467
		Cooling 350	CFM	1386	1395	1403	1409	1413
			Watts	179	240	301	363	426
		Cooling 330	CFM	1307	1317	1324	1330	1334
			Watts	154	211	269	328	388
		Cooling 310	CFM	1228	1238	1246	1251	1254
			Watts	131	185	240	296	352
Cooling 290	CFM	1150	1159	1166	1171	1174		
	Watts	111	162	214	266	320		
Cooling	4.5 Ton	Cooling 450	CFM	2010	2011	2012	2011	2010
			Watts	482	569	657	745	834
		Cooling 420	CFM	1874	1878	1881	1882	1883
			Watts	399	480	562	645	727
		Cooling 400	CFM	1783	1789	1793	1796	1798
			Watts	350	427	505	584	663
		Cooling 370	CFM	1648	1656	1662	1666	1669
			Watts	283	355	427	500	574
		Cooling 350	CFM	1559	1567	1574	1579	1583
			Watts	244	312	381	450	519
		Cooling 330	CFM	1470	1479	1486	1492	1495
			Watts	209	273	338	404	469
		Cooling 310	CFM	1381	1390	1398	1404	1408
			Watts	178	238	299	361	423
Cooling 290	CFM	1292	1302	1310	1315	1319		
	Watts	149	206	264	322	381		
Cooling	5.0 Ton ^(a)	Cooling 450	CFM	2238	2235	2230	2226	2220
			Watts	646	742	840	938	1036
		Cooling 420	CFM	2086	2086	2085	2083	2080
			Watts	533	623	714	806	897
		Cooling 400	CFM	1985	1987	1988	1988	1986
			Watts	466	552	639	726	813
		Cooling 370	CFM	1834	1838	1842	1844	1845
			Watts	377	456	536	617	698
		Cooling 350	CFM	1733	1740	1745	1748	1750
			Watts	324	399	475	552	628
		Cooling 330	CFM	1633	1641	1647	1652	1655
			Watts	277	347	419	492	564
		Cooling 310	CFM	1534	1543	1550	1555	1558
			Watts	234	301	369	437	505
Cooling 290	CFM	1435	1444	1452	1458	1461		
	Watts	196	259	322	387	451		

^(a) Factory Setting.



Maximum Vent Length Table

Model	Maximum Total Equivalent Length in Feet for Vent and Inlet Air (See Notes)	
	2 inch or 2.5 inch Pipe	3 inch or 4 inch Pipe
Altitude 0–2,000 Feet		
S9V2B040U3PS, S9V2B040D3PS, S9V2B060D3PS, S9V2B060U4PS	200	200
S9V2B080U4PS, S9V2B080D4PS, S9V2C080U5PS	100	200
S9V2C100U5PS, S9V2C100D5PS	50	200
S9V2D120U5PS, S9V2D120D5PS	Note 1	200
Altitude 2,001–5,400 Feet		
S9V2B040U3PS, S9V2B040D3PS, S9V2B060D3PS, S9V2B060U4PS	200	200
S9V2B080U4PS, S9V2B080D4PS, S9V2C080U5PS	80	120
S9V2C100U5PS, S9V2C100D5PS	50	150
S9V2D120U5PS, S9V2D120D5PS	Note 1	200
Altitude 5,401–7,800 Feet		
S9V2B040U3PS, S9V2B040D3PS, S9V2B060D3PS, S9V2B060U4PS	100	150
S9V2B080U4PS, S9V2B080D4PS, S9V2C080U5PS	50	70
S9V2C100U5PS, S9V2C100D5PS	Note 1	100
S9V2D120U5PS, S9V2D120D5PS	Note 1	100
Altitude 7,801–10,100 Feet		
S9V2B040U3PS, S9V2B040D3PS, S9V2B060D3PS, S9V2B060U4PS	50	90
S9V2B080U4PS, S9V2B080D4PS, S9V2C080U5PS	Note 1	50
S9V2C100U5PS, S9V2C100D5PS	Note 1	50
S9V2D120U5PS, S9V2D120D5PS	Note 1	50
Notes:		
<ol style="list-style-type: none"> Not allowed For PolyPro® by Duravent, Z-DENS by Novaflex Group, InnoFlue® by Centrotherm, and Polyflue™ manufactured modular venting systems that are in the approved vent pipe material table, fitting equivalent vent lengths may be different from what is shown in Note 6. Refer to the venting system manufacturer's installation instruction for appropriate venting diameters and equivalent lengths. Minimum vent length for all models: 15' equivalent. DO NOT MIX PIPE DIAMETERS IN THE SAME LENGTH OF PIPE OUTSIDE THE FURNACE CABINET (Except adapters at the top of the furnace). If different inlet and vent pipe sizes are used, the vent pipe must adhere to the maximum length limit shown in the table above (See note 7 below for exception). The inlet pipe can be of a larger diameter, but never smaller than the vent pipe. MAXIMUM PIPE LENGTHS MUST NOT BE EXCEEDED! THE LENGTH SHOWN IS NOT A COMBINED TOTAL, IT IS THE MAXIMUM LENGTH OF EACH (Vent or Inlet air pipes). One SHORT radius 90° elbow is equivalent to 10' of 4" pipe, 10' of 3" pipe, or 8' of 2" pipe. One LONG radius elbow is equivalent to 6' of 4" pipe, 7' of 3" pipe, or 5' of 2" pipe. Two 45° elbows equal one 90° LONG elbow. One MITERED elbow is equivalent to 12' of 3" pipe or 12' of 2" pipe. The termination tee or bend must be included in the total number of elbows. If the BAYAIR30AVENTA or BAYAIR30CNVENT termination kit is used, the equivalent length of pipe is 5 feet. For BAYVENT200B and BAYVENTCN200B the equivalent length is 0 feet. For Canadian applications, venting systems must meet ULC-S636 requirements. The INLET AIR of one pipe systems require the installation of a minimum of one 90° elbow (to prevent dust and debris from falling straight into the furnace). 		

S9V2 Wiring Diagram

- NOTES:**
- IF ANY OF THE ORIGINAL WIRING AS SUPPLIED WITH THIS FURNACE MUST BE REPLACED, IT MUST BE WITH WIRE HAVING A TEMPERATURE RATING OF AT LEAST 105°C. WIRES 12, 48, 50, AND 51 REQUIRE A TEMPERATURE RATING OF AT LEAST 250°C.
 - FOR PROPER AIRFLOW IN COOLING/HEAT PUMP MODES, Y1 AND Y2 MUST CONNECT FROM THE THERMOSTAT TO THE IFC LOW VOLTAGE TERMINAL STRIP.
 - FOR COOLING ONLY SYSTEMS, LEAVE Y1-O JUMPER IN PLACE ON THE IFC FOR CORRECT LED READOUT.
 - FOR HEATPUMP SYSTEMS, REMOVE THE Y1-O JUMPER, CONNECT "O" FROM THE THERMOSTAT TO "O" ON THE IFC LOW VOLTAGE TERMINAL STRIP FOR CORRECT LED READOUT AND DEFROST OPERATION.
 - VSPD OD SYSTEMS REQUIRE DIFFERENT CONNECTIONS. SEE RELAY PANEL INSTRUCTIONS.
 - IF USING A SINGLE STAGE HEATING THERMOSTAT, JUMPER W1 AND W2 TERMINALS AT THE LOW VOLTAGE TERMINAL STRIP, HT2 WILL BE SHOWN ON THE SEVEN SEGMENT DISPLAY AT ALL TIMES. SECOND STAGE OPERATION WILL BEGIN AFTER THE INTERSTAGE DELAY HAS COMPLETED.
 - TO CHANGE AIRFLOW, REFER TO THE INTEGRATED FURNACE CONTROL MENU AND OPTIONS TO SET AIRFLOW AND BLOWER DELAYS.
 - THE "BK" JUMPER MUST BE CUT WHEN APPLYING AN AIRFLOW COMMAND TO THE "BK" TERMINAL, SUCH AS PULSE WIDTH MODULATION.
 - CORRECT PERSONALITY MODULE IS REQUIRED FOR PROPER FURNACE OPERATION AND IS SPECIFIC TO EACH MODEL & SERIAL NUMBER. IT IS TO REMAIN WITH THE ORIGINAL UNIT.
 - WIRE YL4S AND RAF-2 ARE NOT PRESENT ON DOWNFLOW MODELS.
 - FLAME SENSE TEST PADS: 1 VDC = 1 MICROAMP. FLAME CURRENT CAN VARY DEPENDING ON THE VOM THAT IS USED AND THE VOLTAGE SUPPLIED TO THE FURNACE. THE ACCEPTABLE RANGE IS 0.75-3 MICROAMPS.

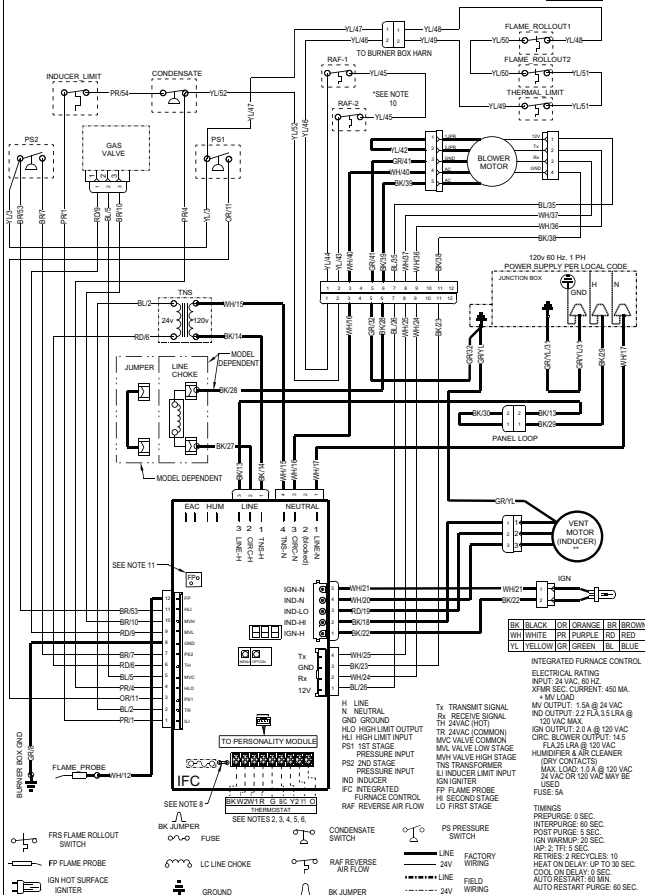

Status Codes	Set/	Outdoor Unit	EC4	Open Thermal Limit, Rollout Switch, or Reverse Airflow Switch
Idle	CF	Blower Constant Fan Airflow Multiplier %	EE1	Voltage reversed polarity
H1	1st Stage Heating	CFM	EE2	Bad Grounding
H2	2nd Stage Heating	CPH	EE3	(1) Igniter relay fails, (2) Igniter open
RAF	Airflow (followed by Airflow x 10)	Had	E11	1st stage gas valve (MV1) is energized when it should be off
CFD	Continuous Fan	1.5d	EDB	Flame current is low, but still strong enough to allow operation.
LL	1st Stage Cooling	SHC	ED9	Open Inducer Limit Switch or Condensate Switch
EL	2nd Stage Cooling	rUn	E11	(1) 1st stage gas valve not energized when it should be (2) 1st stage gas valve relay stuck closed (3) 2nd stage gas valve relay stuck closed (4) 2nd stage gas valve energized when it should not be (5) 2nd stage gas valve not energized when it should be
HP1	1st Stage Heat Pump	ED1	E12	Blower HPOEM ID
HP2	2nd Stage Heat Pump	E21	E13	No PM and local copy bad
dF	Defrost Mode	E22	E15	Both Unit Data File in PM and local Unit Data File are Corrupt
Menu Options			E17	Blower motor no communication response
Err	Active Alarm Menu	E23	E18	Blower communication failure on the control
LGF	Last 6 Faults (To Clear, Hold Option Button 5 sec)	E31		
Cd	Cooling Off Delay (sec)	E32		
Det	Outdoor Tonnage	E33		
		E34		

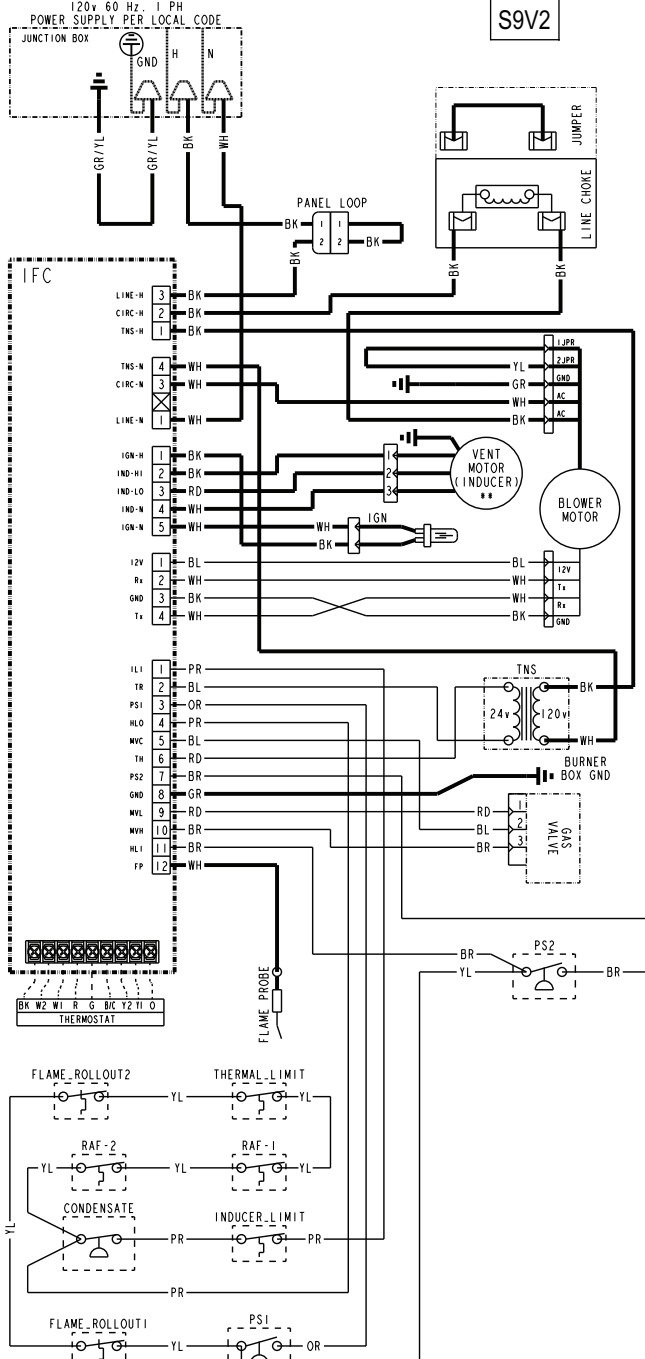



Electrical Connections

Make wiring connections to the unit as indicated on enclosed wiring diagram. As with all gas appliances using electrical power, this furnace shall be connected into a permanently live electric circuit. It is recommended that furnace be provided with a separate "circuit protection device" electric circuit. The furnace must be electrically grounded in accordance with local codes or in the absence of local codes with the National Electrical Code, ANSI/NFPA 70 or CSA C22.1 Electrical Code, if an external electrical source is utilized. **The integrated furnace control is polarity sensitive.** The hot leg of the 120V power supply must be connected to the black power lead as indicated on the wiring diagram. Refer to the Wiring Diagram in this document and Unit Wiring Diagram attached to the furnace.

⚠ WARNING

FIRE HAZARD!

Failure to follow this Warning could result in property damage, severe personal injury, or death.

This Warning applies to installations with a flammable refrigeration system. The furnace must be powered except for service. The furnace shall be installed and connected according to installation instructions and wiring diagrams that are provided with the evaporator coil.

Field Wiring

FIELD WIRING DIAGRAM FOR S9V2 WITH ONE / TWO STAGE AC OR HEAT PUMP

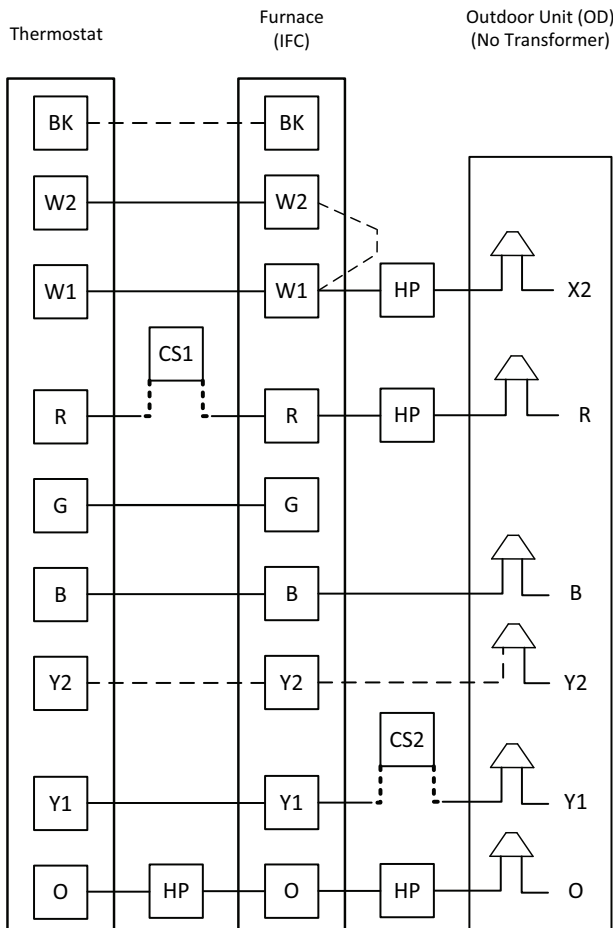

NOTES:

- 1) HP = Wiring used for Heat Pump System.
- 2) CS = wiring used for Condensate Switch (2 Options).
- 3) Y1 and/or Y2 must be connected from the thermostat to the IFC for proper airflow.
- 4) Remove Y1-O jumper for HP systems. O terminal must be connected as shown for gas heating operation during defrost.
- 5) If the thermostat does not have a W2, or there are not enough conductors, jumper W1 to W2 at the IFC.
- 6) A/TCONT824 thermostats do not require the use of X2.
- 7) For PWM (BK) enabled thermostats, cut the BK jumper on the IFC and connect wiring.

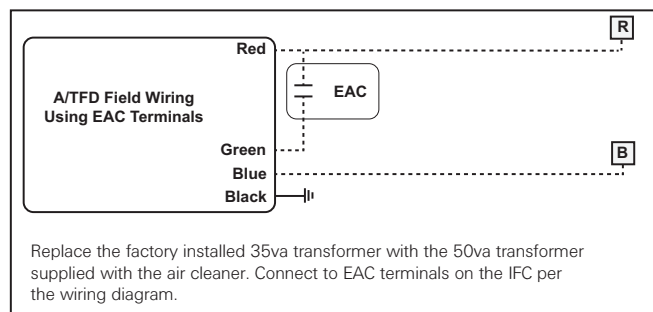

Replace the factory installed 35va transformer with the 50va transformer supplied with the air cleaner. Connect to EAC terminals on the IFC per the wiring diagram.

FIELD WIRING DIAGRAM FOR S9V2 WITH SINGLE STAGE AC OR HEAT PUMP WITH 2 STAGE AIRFLOW

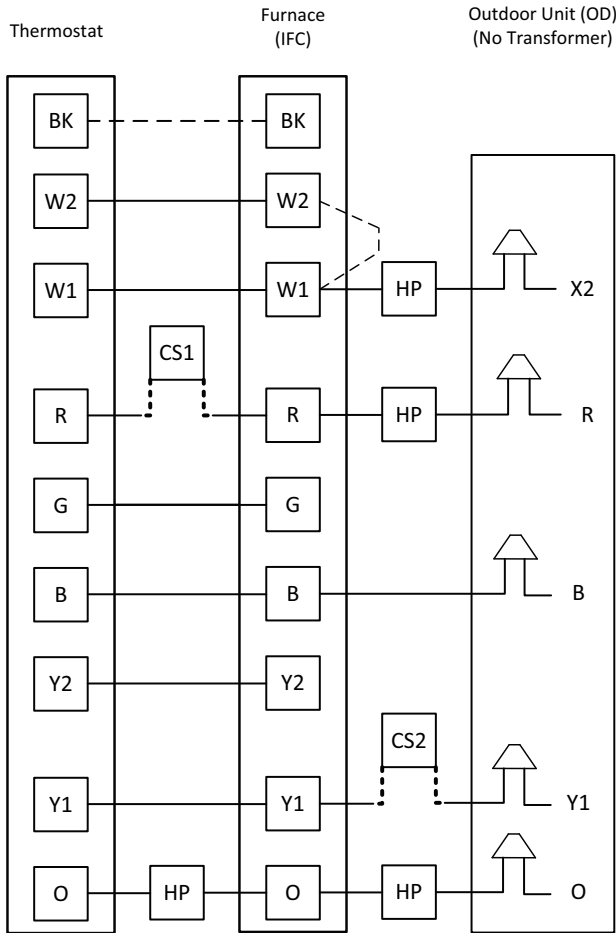

NOTES:

- 1) HP = Wiring used for Heat Pump System.
- 2) CS = wiring used for Condensate Switch (2 Options).
- 3) Y1 and Y2 must be connected from the thermostat to the IFC for proper airflow.
- 4) Thermostat must be setup for 2 stage OD.
- 5) IFC Must be setup for 2 stage OD using the Menu/Option Buttons.
- 6) Remove Y1-O jumper for HP systems. O terminal must be connected as shown for gas heating operation during defrost.
- 7) If the thermostat does not have a W2, or there are not enough conductors, jumper W1 to W2 at the IFC.
- 8) A/TCONT824 thermostats do not require the use of X2.
- 9) For PWM (BK) enabled thermostats, cut the BK jumper on the IFC and connect wiring.

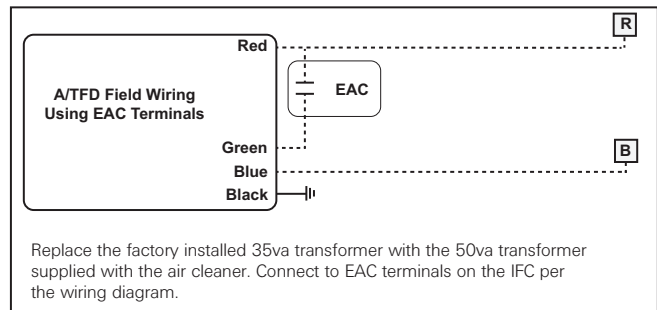



Trane - by Trane Technologies (NYSE: TT), a global innovator - creates comfortable, energy efficient indoor environments for commercial and residential applications. For more information, please visit trane.com or tranetechnologies.com.



Trane has a policy of continuous data improvement and it reserves the right to change design and specifications without notice. We are committed to using environmentally conscious print practices.